

2. Installation

Receiving and Inspection

- Inspect for damage.
- Packing List - verify correct configuration against Ordering Information Sheet (OIS) located at the rear of this manual in the plastic sheet protector.
- If the above items are satisfactory then proceed with installation. If not, then STOP and contact the field representative or the factory personnel for instructions.

Packing, Shipping and Returns

These issues are addressed under Customer Service in Appendix A.

Vortab Insertion Sleeve (VIS) Flow Conditioner Installation

Prepare the installation site or inspect the already prepared location to assure that the VIS will fit into the process pipe or duct.

- Verify that the VIS matches the geometry and dimensions of the intended process pipe mount.
- The outlet of the VIS must be located 4 nominal pipe diameters upstream from the customer meter. The process pipe must continue straight for at least 1 pipe diameter past the customer meter. See Figure 2-1.
- Remove the sizing ring, a hammer may be required.

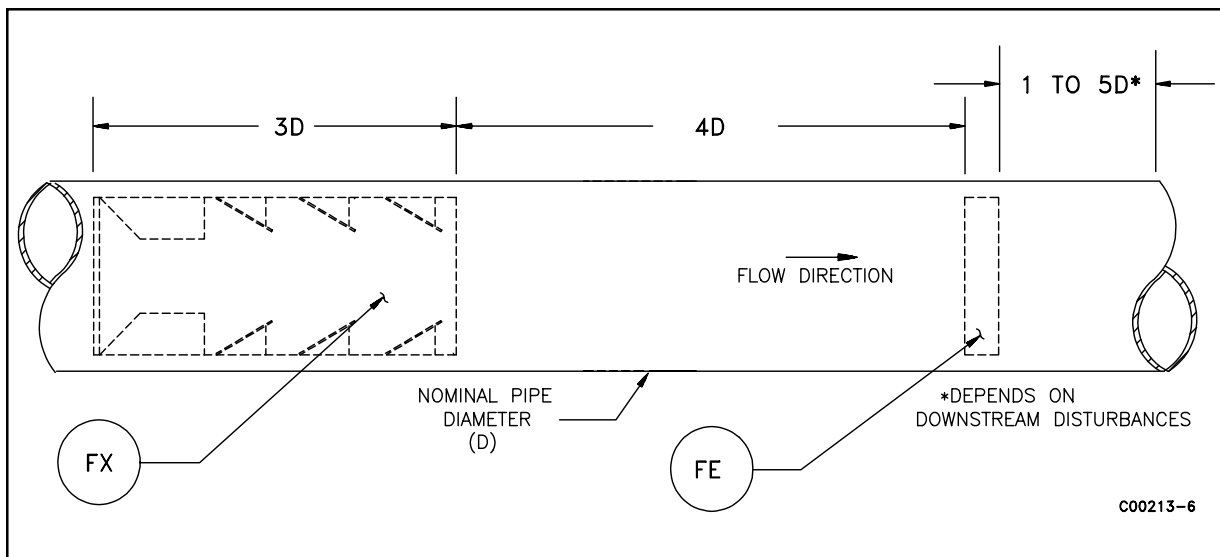

Figure 2-1. Orientation of VIS in Process Pipe or Duct

Tack Weld Mounting

Slide the VIS into the process pipe. The tabs should be approximately aligned with the customer port. Tack weld the VIS into the process pipe to hold it in place. See Figure 2-2.

If the VIS does not fit, use the sizing ring to determine where the flow conditioner is out-of-round. Carefully reshape the problem area and reinstall the VIS.

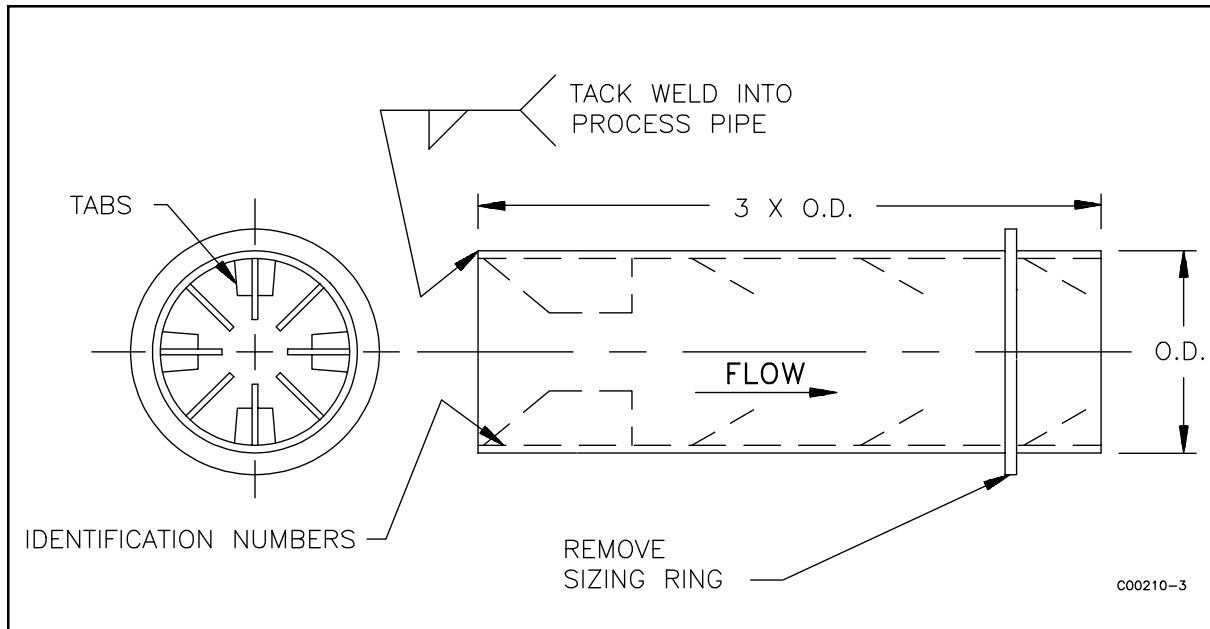

Figure 2-2. Typical Tack Weld Installation of an VIS

Retaining Wafer Mounting

Install gaskets on both sides of the flange. Slide the VIS into the process pipe. The tabs should be approximately aligned with the customer port. Bolt the wafers together. See Figure 2-3.

If the VIS does not fit, use the sizing ring to determine where the flow conditioner is out-of-round. Carefully reshape the problem area and reinstall the VIS.

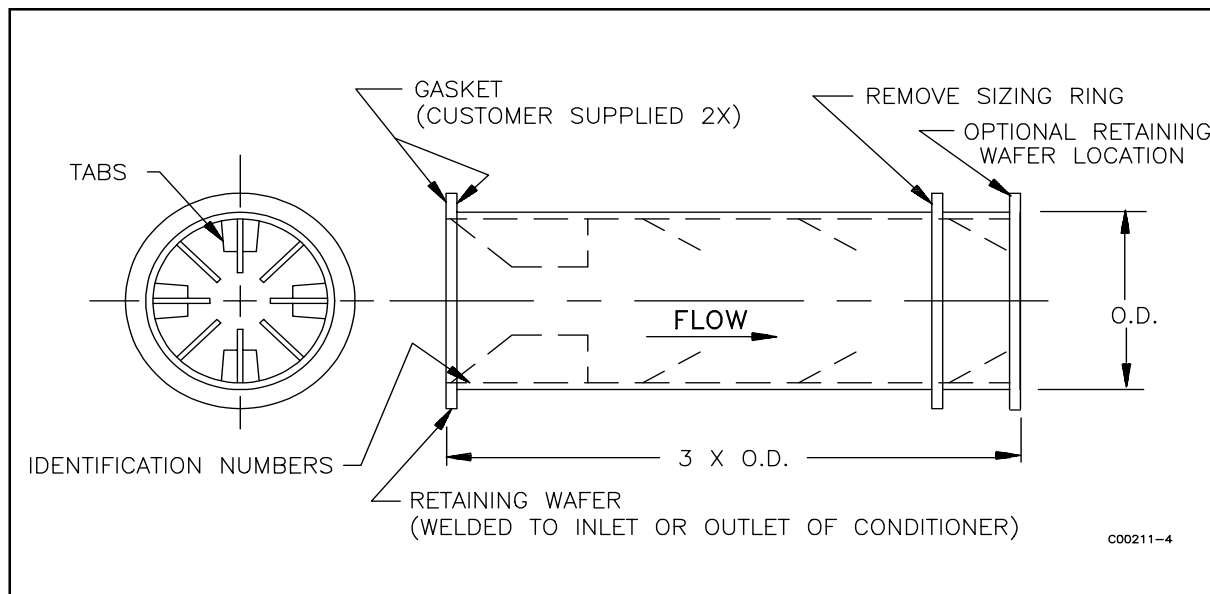

Figure 2-3. Typical Retaining Wafer Mounting of a VIS

Vortab Meter Run (VMR) Flow Conditioner Installation

Prepare the installation site or inspect the already prepared location to assure that the VMR will fit into the process by verifying that the VMR matches the geometry and dimensions of the intended process pipe.

Butt Weld Mounting

Weld the VMR in place. See Figure 2-4.

Install the flow element. Be sure the flow element is aligned properly.

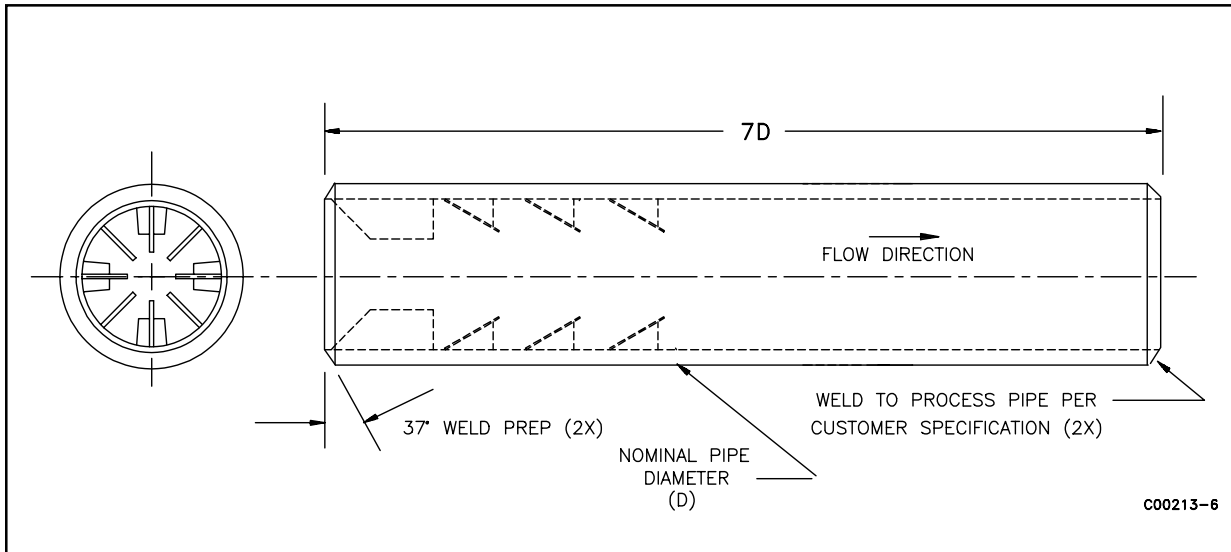

Figure 2-4. Typical Butt Weld Mounting of a VMR

Flange Mounting

Install gaskets on both flanges. Bolt the VMR in place. See Figure 2-5.

Install the customer application (i.e. flow element) into the customer port. Be sure the application is aligned properly.

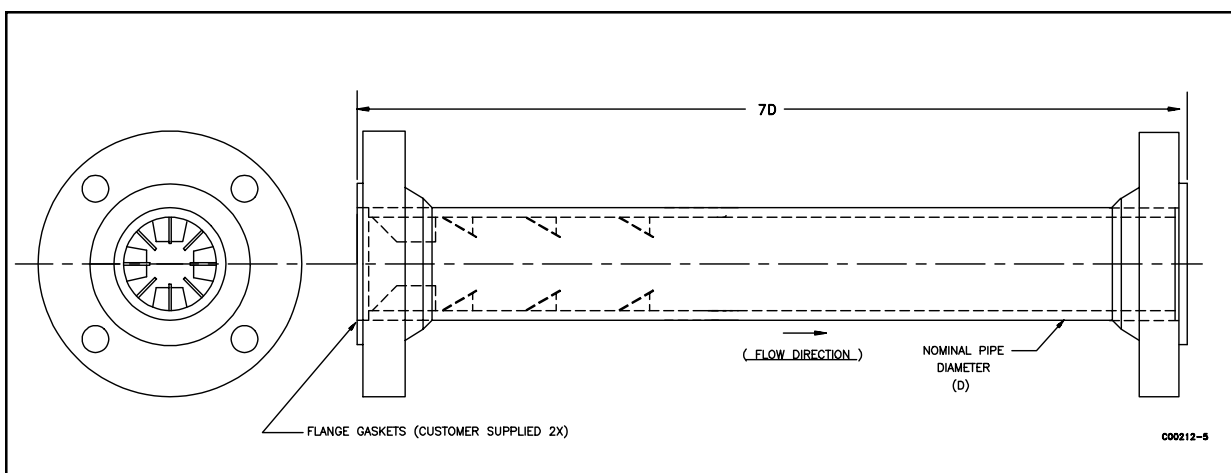

Figure 2-5. Typical Flange Mounting of a VMR

Vortab Short Run (VSR) Flow Conditioner Installation

Prepare the installation site or inspect the already prepared location to assure that the VSR will fit into the process by verifying that the VSR matches the geometry and dimensions of the intended process pipe.

Butt Weld Mounting

Weld the VSR in place. See Figure 2-6.

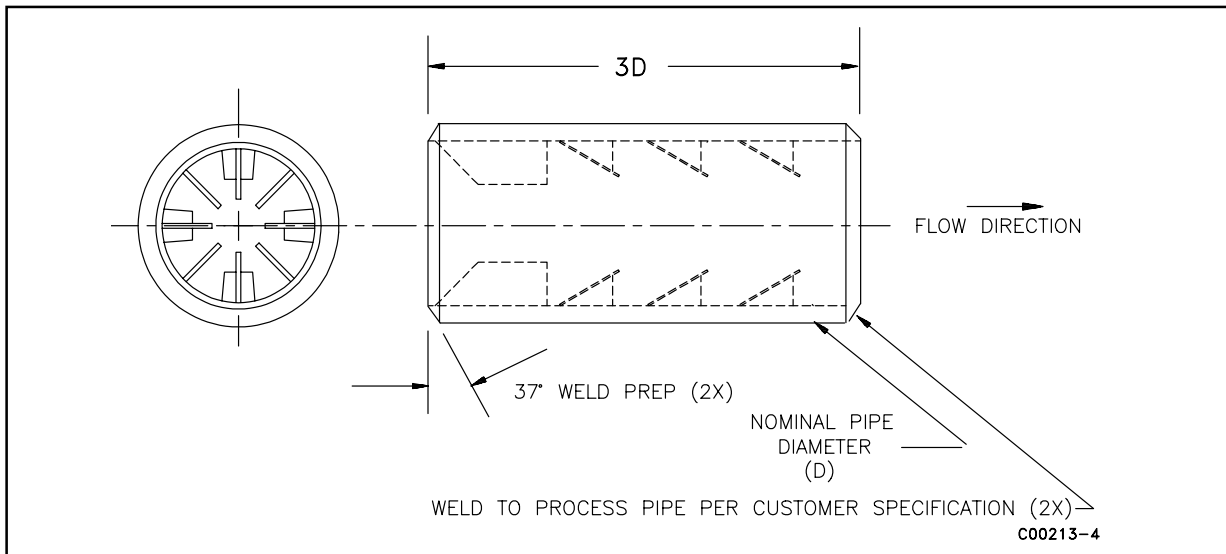

Figure 2-6. Typical Butt Weld Mounting of a VSR

Flange Mounting

Install gaskets on both flanges. Bolt the VMR in place. See Figure 2-7.

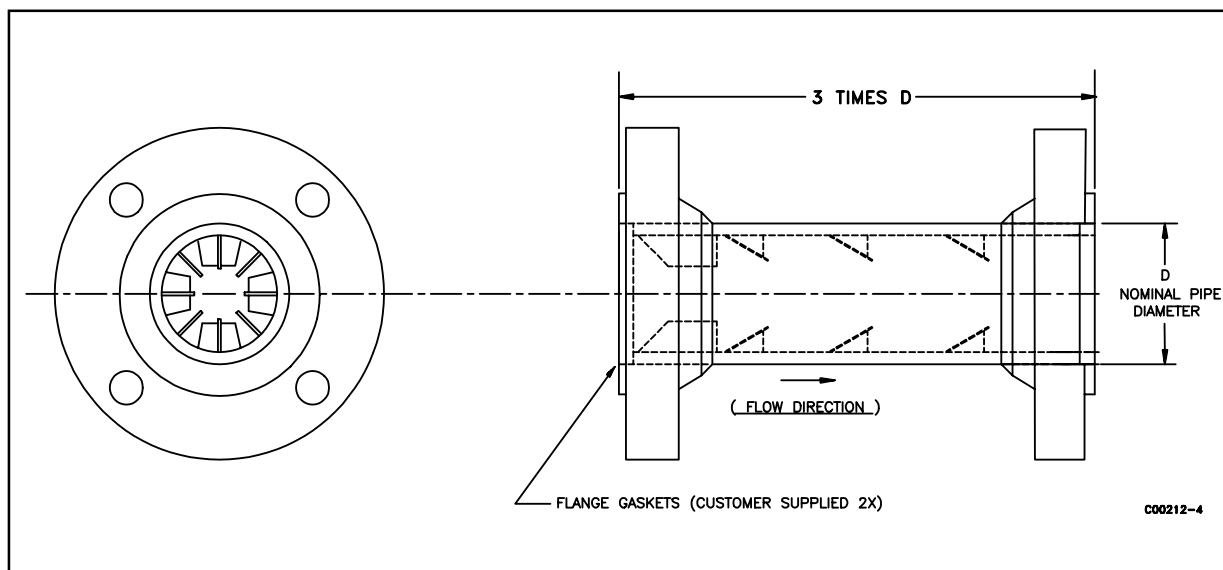

Figure 2-7. Typical Flange Mounting of a VSR

Vortab Field Kit (VFK) Flow Conditioner Installation

Process Pipe Preparation

The outlet of the assembled VFK must be 4 outside pipe diameters upstream from the customer meter. The process pipe must continue straight for at least 1 pipe outside diameter downstream past the customer port. See Figure 2-8.

Ensure the VFK assembly location is clean. Mark the tab locations of the VFK starting at 3 outside pipe diameters upstream from the customer port and continuing through the end of the VFK (3 inside pipe diameters). See Figure 2-8. The easiest method of assembly is to access the VFK assembly area from both ends for welding.

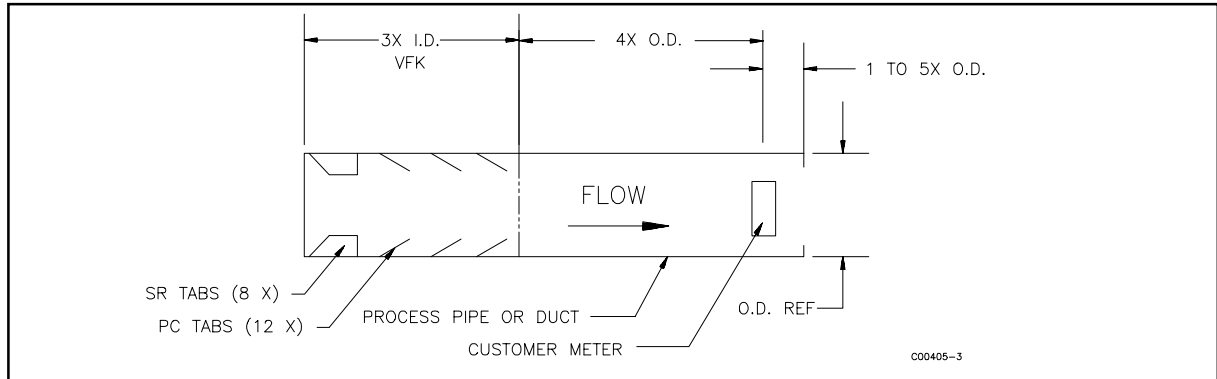

Figure 2-8. Orientation of VFK in Process Pipe or Duct

Tab Placement Calculation

Use Table 2-1 to calculate the dimensions for depth placement of the Swirl Reduction (SR) and Profile Conditioning (PC) tabs in the process pipe.

Table 2-1. Depth Placement Dimensions (Inches)

Dimensions	Pipe or Duct Inside Diameter	A Dimension	B Dimension	C Dimension	D Dimension
Equations	Pipe O.D. - (2 x wall thickness)	0.083 x I.D. (8 SR Tabs)	0.743 x I.D. (4 PC Tabs)	1.687 x I.D. (4 PC Tabs)	2.631 x I.D. (4PC Tabs)
Customer Calculation					

Measuring from the VFK inlet, mark the inside of the process pipe for depth placement of tabs (Dimensions A, B, C, and D). See Table 2-1 and Figure 2-9. Mark the inside of the process pipe for radial placement of tabs at each depth mark. Place the first radial mark in line with the customer port (i.e., flow element). For the swirl reduction tabs (Dimension A), radial placement must be every 45° from the first radial mark. For the Profile Conditioning tabs (Dimensions B, C, and D), radial placement must be every 90° from the first radial mark. See Figure 2-10.

Welding Procedures

The easiest way to install the VFK is to have access to the VFK assembly location from both ends for welding. However, if only one end is accessible, follow the appropriate procedures below.

A. Recommended Weld Procedure - Access From Both Ends:

1. Spray the inside of process pipe with anti-spatter.
2. Fillet weld gussets (Item 3) to center line of PC tabs (Item 2) with intermittent welds, .50 inches long on 1.5 inch centers (approximately) per Figure 2-9.
3. Weld the first row (Dimension B) of PC tab assemblies from Step 2, to the inside of the process pipe every 90° using the same weld process per Figure 2-9. Thoroughly clean all weld spatter and slag from the process pipe. Sand blast if possible.
4. Repeat the process for rows 2 and 3 (Dimensions C and D). Thoroughly clean all weld spatter and slag from process pipe. Sand blast if possible.

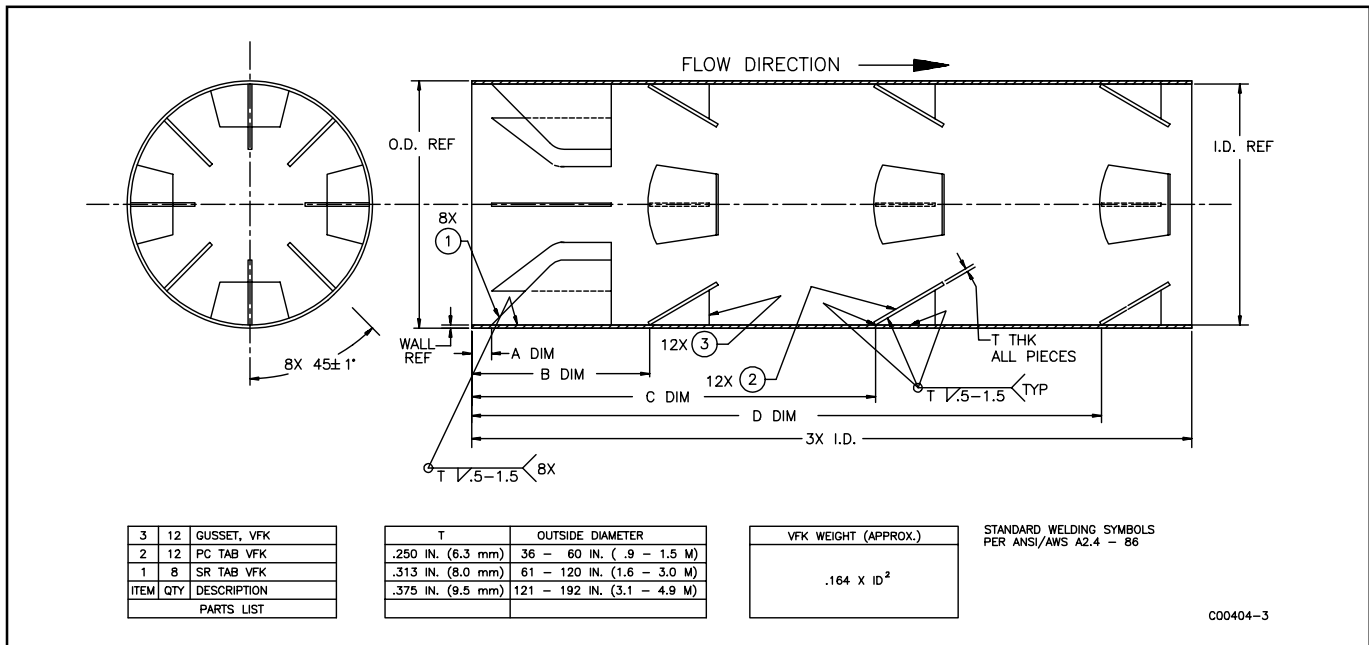

Figure 2-9. VFK Assembly Drawing

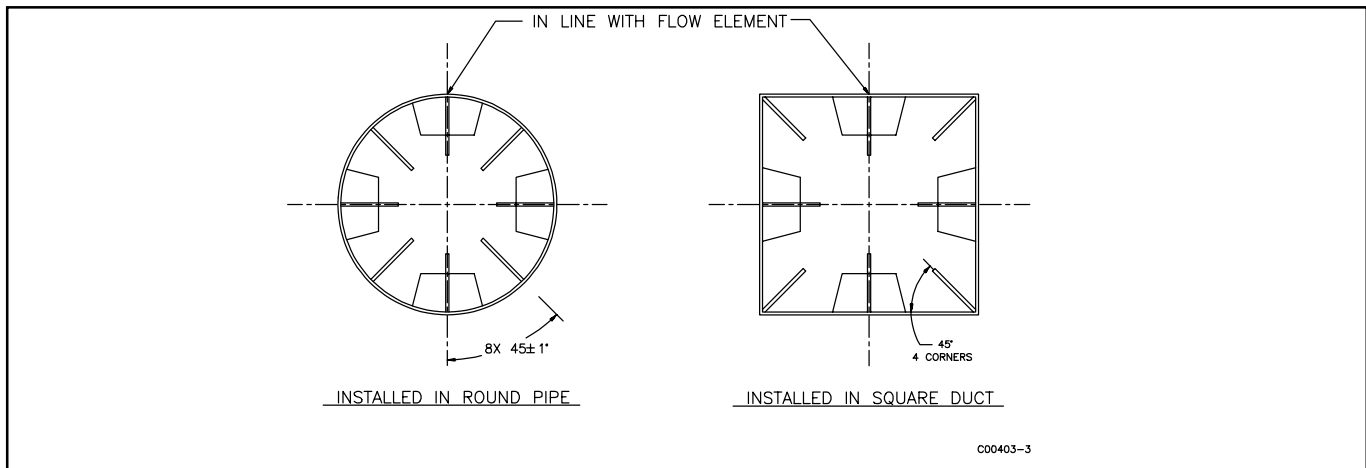

Figure 2-10. Radial Placement

- Weld eight (8) SR tabs (Item 1) every 45° using the same weld process per Figure 2-9. Thoroughly clean all weld spatter and slag from process pipe. Sand blast if possible.

B. Alternative Weld Procedure - Access from the Downstream (Outlet) End:

- Spray inside of the process pipe with anti-spatter.
- Fillet weld gussets (Item 3) to the center line of PC tabs (Item 2) with intermittent welds, .50 inches long on 1.5 inch centers (approximately), per Figure 2-9.
- Weld eight (8) SR tabs (Item 1) to the inside of the process pipe every 45° using the same weld process per Figure 2-9. Thoroughly clean all weld spatter and slag from the process pipe.
- Weld the first row (Dimension B) of PC tab assemblies from Step 2, to the inside of the process pipe every 90° using the same weld process per Figure 2-9. Thoroughly clean all weld spatter and slag from the process line. Sand blast if possible.
- Repeat the process for rows 2 and 3 (Dimensions C and D).

C. Alternative Weld Procedure - Access from the Upstream (inlet) End:

- Perform steps 1 and 2 from the alternative weld procedure shown above then do steps 3, 4, and 5 in the reverse order.