

GF92 Installation, Operation and Troubleshooting Guide

- A. To get the best results from the instrument, the sensor should be located 20 pipe diameters downstream from any flow disturbance (valve, pipe elbow, etc.) and 10 pipe diameters upstream from any disturbance.

The instrument tags show the model number, tag number (if noted on the customer's order), serial number along with other important safety information. Compare this information with the appropriate pipe installation drawings and calibration sheets to verify the instrument is the correct configuration.

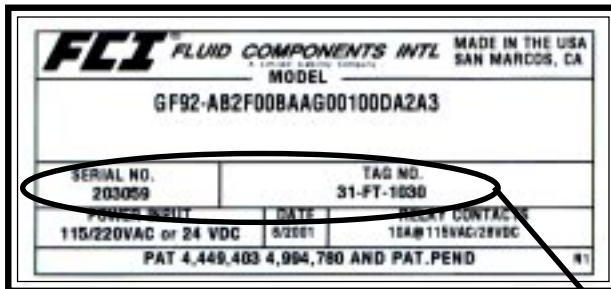

Tag Location - Between Conduit Ports
On Local Enclosure

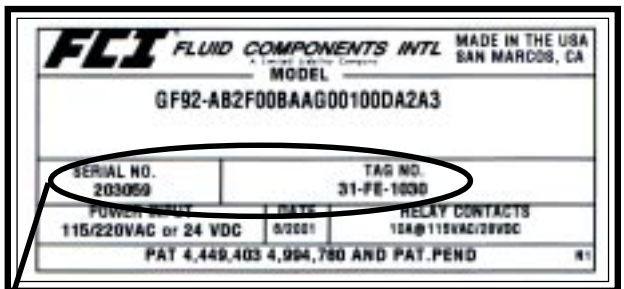

Tag Location - Top Side of
Remote Enclosure

If the instrument is a remote configuration, the serial number on the enclosure tags must match. The recommended tag number on the local enclosure will have an FT in the tag number. The recommended tag number on the remote enclosure will have an FE in the tag number. (Tags are specified by the customer, "FE/FT" is a recommended naming convention.)

- B. Verify the serial numbers on the enclosure(s), flow element and electronics match. The instrument may not work if the serial numbers do not match. (The instrument has a remote transmitter enclosure (FT) and a local flow element enclosure (FE).)



Flow Element Serial Number
Also Showing Flow Arrow
(Located near the FE enclosure.
It is also on the enclosure tag.)

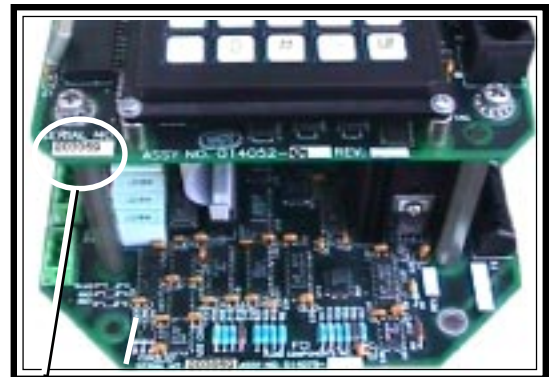

Electronics Serial Number
(Top circuit board, lower left corner. It is also on the transmitter's (FT) enclosure tag.)

- C. Recommended installation/troubleshooting tools are an open-ended wrench to fit the NPT connection, an open-ended wrench to fit the flanged fitting nuts and bolts, a small flat blade screw driver for manipulating potentiometers, both a medium flat blade screwdriver and a medium phillips head screwdriver for tightening connections, 3 mm allen wrench for CENELEC approved instruments, a measuring tape for proper flow element placement, and a DVM for Ohm/Voltage measurements.

Step 3. Wiring Preparation

Before the instrument is opened to install the wiring, FCI recommends that the following ESD precautions be observed:

Use a wrist band or heel strap with a 1 megohm resistor connected to ground. If the instrument is in a shop setting there should be static conductive mats on the work table and floor with a 1 megohm resistor connected to ground. Connect the instrument to ground. Apply antistatic agents such as Static Free made by Chemtronics (or equivalent) to hand tools to be used on the instrument. Keep high static producing items away from the instrument such as non-ESD approved plastic, tape and packing foam.

The above precautions are minimum requirements to be used. The complete use of ESD precautions can be found in the U.S. Department of Defense Handbook 263.

Open the instrument enclosure to expose the terminal strips. The orientation of the connectors are shown below:

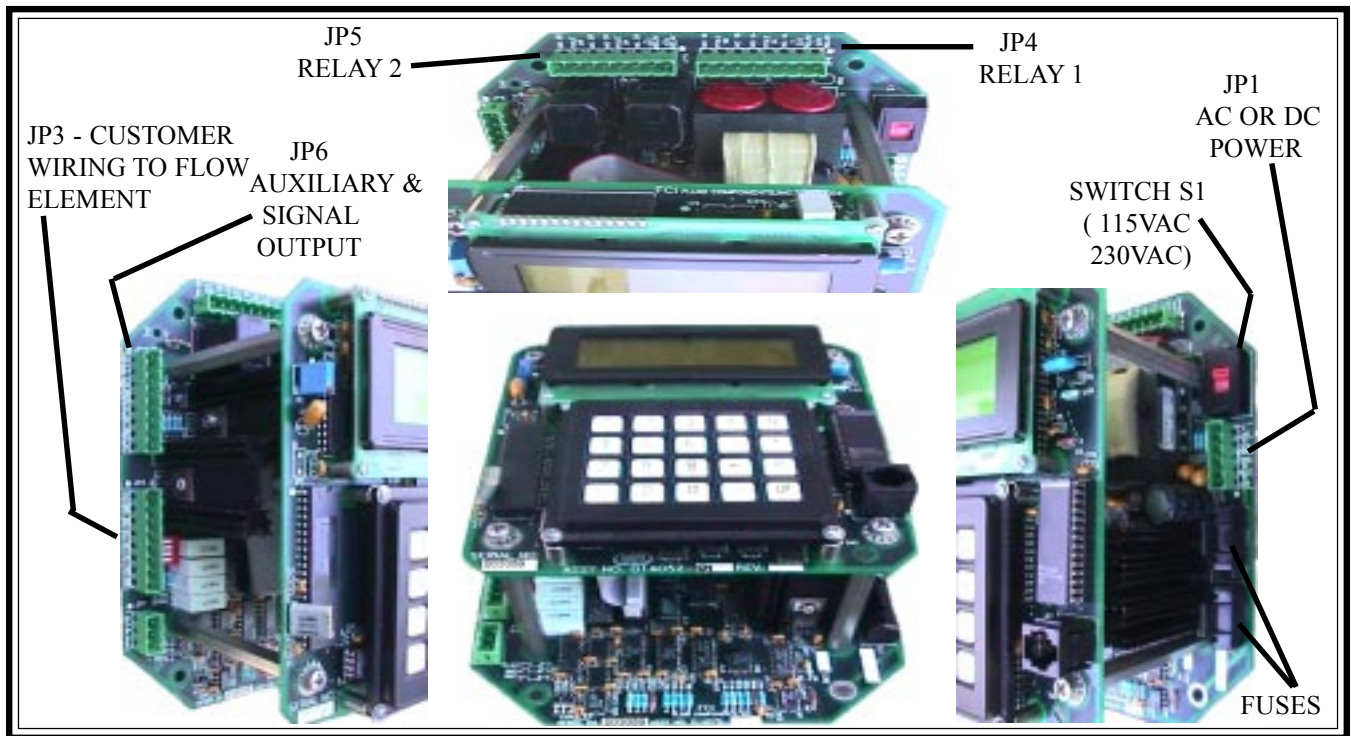

GF92 Terminal Strip, Power Option Switch and Fuse Orientation

Step 4. Wiring the Instrument



Caution:

Only qualified personnel are to wire or test this instrument. The operator assumes all responsibilities for safe practices while wiring or troubleshooting.



Alert:

The instrument contains electrostatic discharge (ESD) sensitive devices. Use standard ESD precautions when handling the flow transmitter.

Wiring the Instrument into the Customer Application:

This section describes wiring to the transmitter inputs, outputs and interconnection cabling for the remote enclosure. For best results route the output wiring through the opposite port from the power wiring. See the table on the next page to determine the size of wiring to be used versus the length of the wire.

Wire Gauge Versus Distance Of Wire To Run

Wiring the Instrument's Signal Output to the Customer Application:

For Current Output: 4 - 20 mA; connect a positive wire to + I OUT and a negative wire to OUT COM.

For Voltage Output: 0 - 5, 0 - 10 or 1 - 5 Vdc; connect a positive wire to + E OUT and a negative wire to OUT COM.

Analog Output 2 is connected in a similar manor as Analog Output 1. (For Voltage Output: 0 - 5, 0 - 10 or 1 - 5 Vdc; connect a positive wire to + E OUT2 and a negative wire to OUT 2 COM. For Current Output: 4 - 20 mA; connect a positive wire to + I OUT2 and a negative wire to OUT 2 COM.) See GF Series manual 06EN003229 for details.

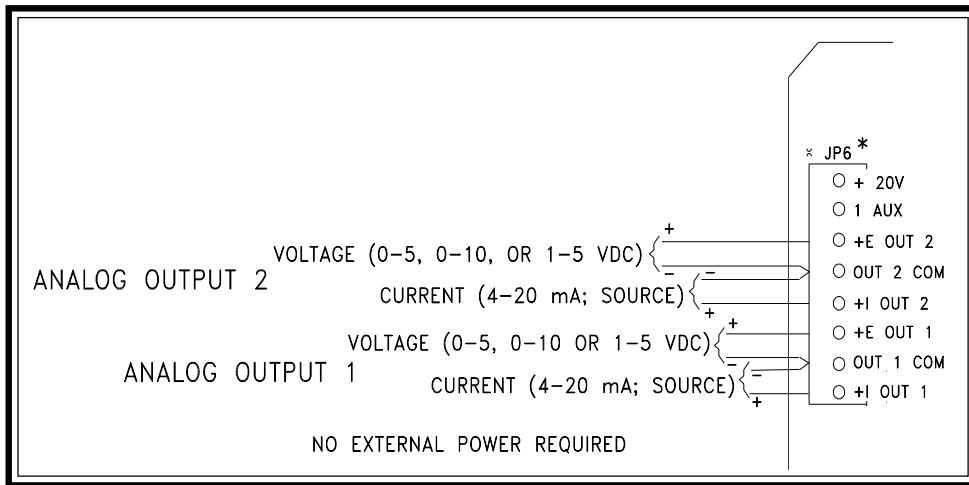

Customer Connections, Analog Output Diagram

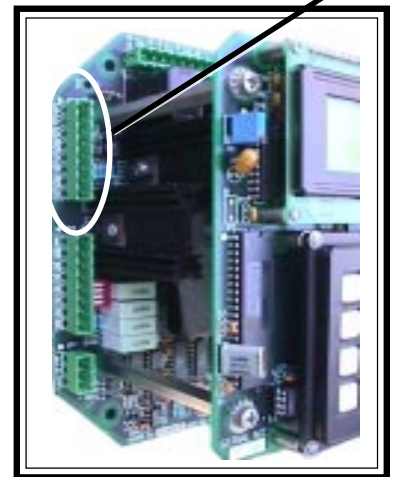

Analog Output Plug Location

Alert: Either voltage or current from the Analog Outputs can be connected to the customer application, not both. (Example: Voltage and current from analog output 1 cannot be connected.) However, one Analog Output can be wired for current and the other Analog Output can be wired for Voltage.

Wiring the Flow Element:

Connect a shielded, 8 wire cable between the transmitter and the local enclosure terminal strip as shown below. Be sure the shield (ground wire) is connected to JP3 GND along with the wire from terminal block terminal 2. Do not connect the shield to the local enclosure (leave it floating).

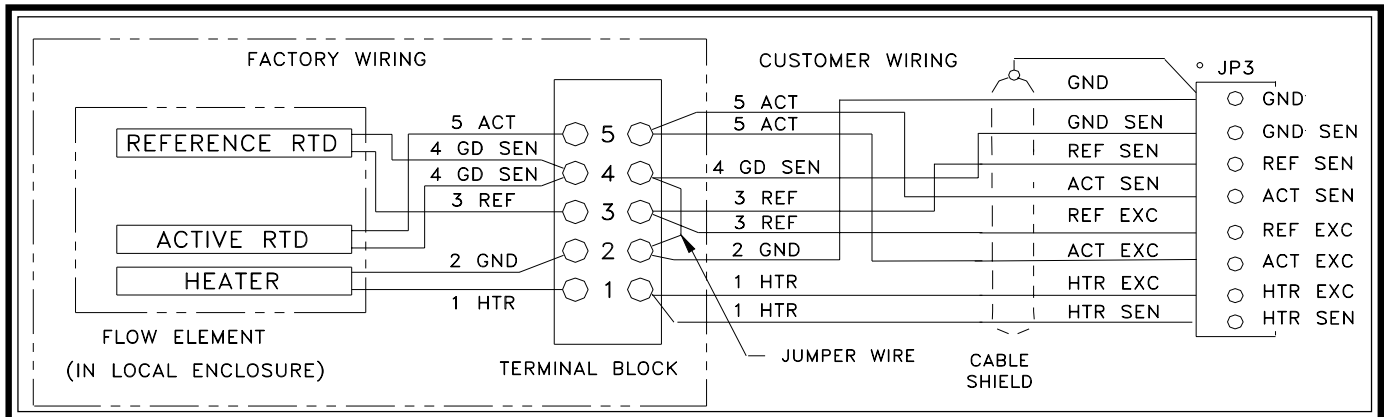

Local Enclosure Wiring Diagram



Flow Element Wiring Diagram
(Be sure the jumper is in place Terminal 2 to terminal 4.)

Flow Element Terminal Block	Transmitter JP3 (Terminal No.)
Terminal 5 (ACT)	ACT SEN (4)
Terminal 5 (ACT)	ACT EXC (6)
Terminal 4 (GND SEN)	GND SEN (2)
Terminal 3 (REF)	REF SEN (3)
Terminal 3 (REF)	REF EXC (5)
Terminal 2 (GND)	GND (1)
Terminal 1 (HTR)	HTR EXC (7)
Terminal 1 (HTR)	HTR SEN (8)

Flow Element Wiring Table



Connector JP3

Wiring the Output Relays:

The instrument contains two sets of alarm output relays (connectors JP4 Relay Output 1, and JP5 Relay Output 2). They can be wired by the customer as desired. (NO = Normally Open, NC = Normally Closed, Pole = Common)

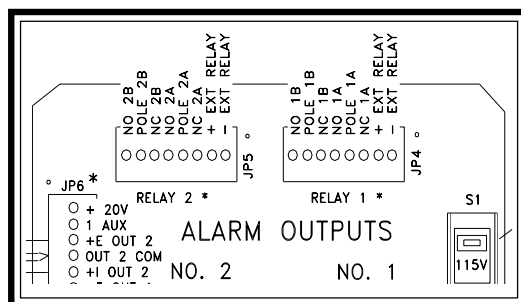

Output Relay Wiring Diagram

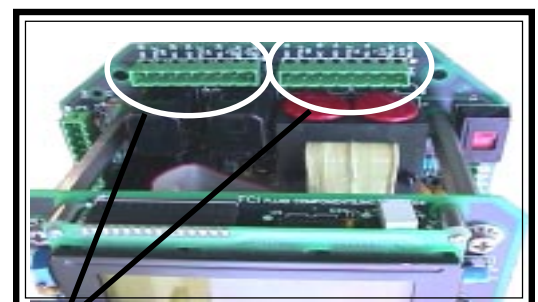

Connectors JP5 and JP4

Wiring the Input Power:



Caution:

FCI recommends placing an ON/OFF switch in line with the power source. When JP1 is connected to the power source the instrument is ON.

AC or DC power can be used to operate this instrument. For best results route the output signal wiring through the left port of the instrument enclosure and the power input wiring through the right port. See the wiring table on Page 4 to determine the minimum size of wiring to be used versus the length of the wire run to the power source.

115 or 230 VAC Power Option

The input power can be switched from 115 Vac to 230 Vac by moving switch S1 to the correct setting. (The instrument requires only AC or DC to be connected, not both.) Connect the hot side of the AC Line to AC Line, the neutral side to AC NEUT, and ground to EARTH GND. (Do not connect the local enclosure shield wire to the EARTH GND on this plug.)

24 VDC Power Option

If DC power is used, the AC Input and switch S1 are not pertinent. Wire the positive 24 volt input to +24V. Connect the negative wire to DC GND.

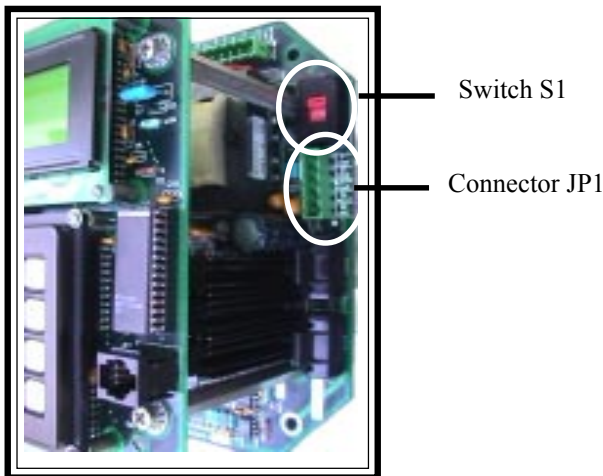

Input Power Location

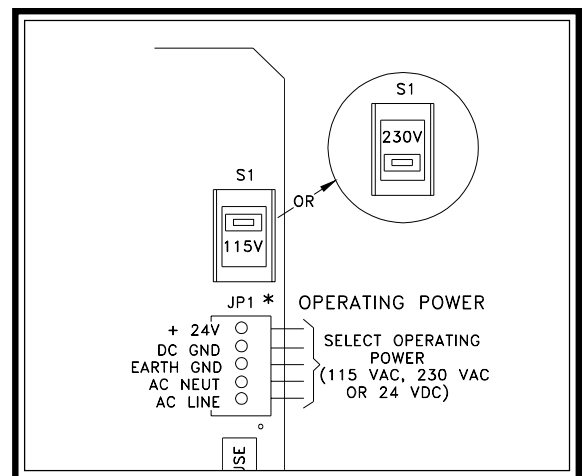

Input Power Wiring Diagram

Step 5. Operation

The instrument has been configured and calibrated to custom specifications. In-depth programming of the instrument in the field should not be necessary.

Apply power to the instrument. Wait 10 minutes for the instrument to stabilize. During this period the instrument may indicate a high flow condition. When the instrument is powered up, the instrument will display an initialization sequence. Then the instrument will display the normal operation information. Shown below is the normal operation window.

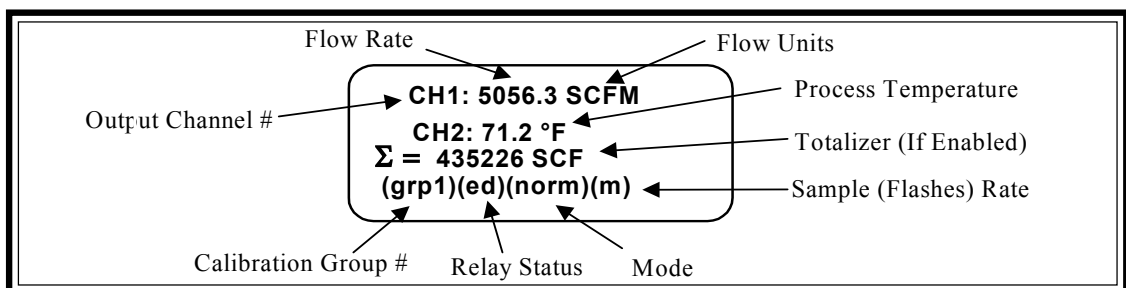

Normal Operation Window

Menu Control

The prompt line displays appropriate key strokes for the required menu level. If a key is pressed that is not valid for that menu, Invalid Response will flash briefly across the prompt line. The key pad and key assignments are shown below:

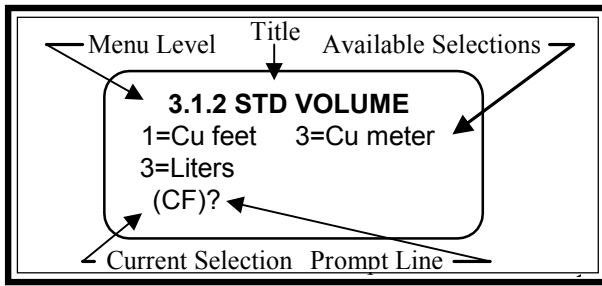

Display Characteristics

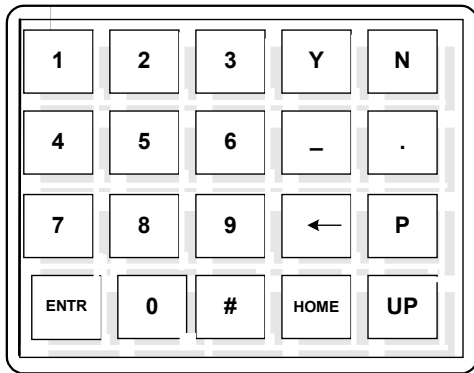

Key Pad

Key	Key Name	Action
0 - 9	Numeric	Selects options and enters numbers
Y	Yes	Enter a yes response
N	No or (N)ext	Enter a no response or scrolls to the next screen
-	Minus	Enter a minus sign
.	Decimal Point	Enter a decimal point
	Back Space	Moves cursor back one space
P	(P)rv or Previous	Scrolls to the previous screen
ENTR	Enter	Enters a numeric value or response
HOME	Home	Returns to the Main Menu or escapes from routines
UP	Up	Move current menu up one level

Key Assignments

At any time, the HOME key can be pressed and the main menu will display. HOME can be used to escape from most routines, or restart a progression into the menu structure.

When (N)ext is displayed on the prompt line, more than two menu selections are available. Press N to scroll through all the selections.

The UP key, will back-out of a menu level. The menu moves back one level each time the UP key is pressed. The UP key only functions when UP is displayed on the prompt line.

To make a selection, press the numeric key associated with the desired menu selection. The selection does not have to be displayed, but it must be one of the available selections.

The quick operation menu is shown below:

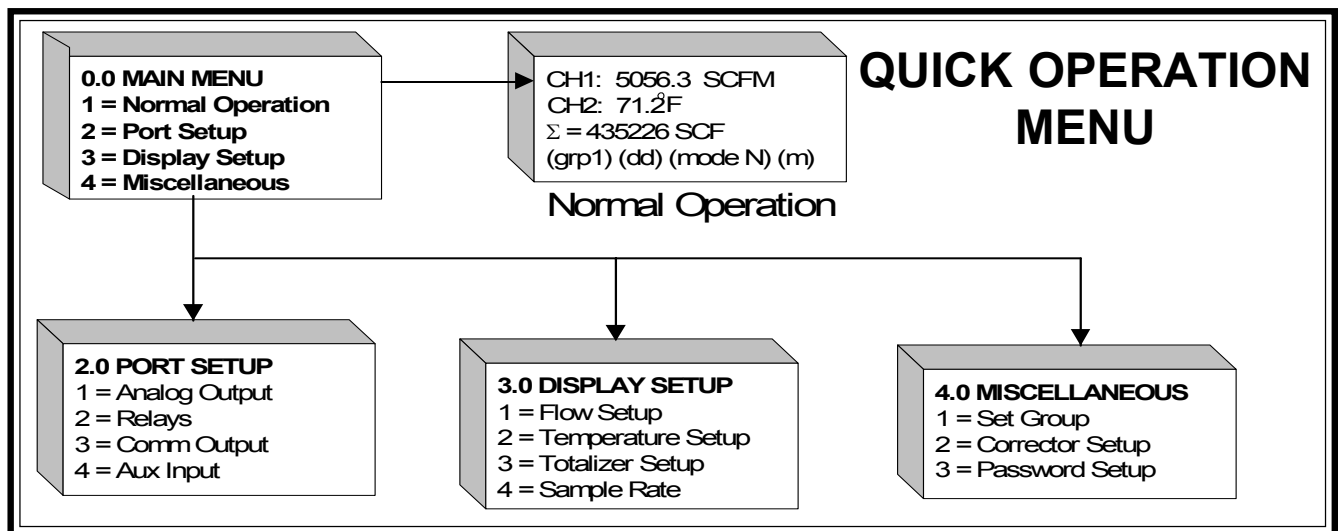

Step 6. Troubleshooting

In the event that the instrument does not operate as expected use the table below:

Problem	Solution
No Display	Check Fuses (below JP1). Verify S1 is switched to the correct input voltage for AC applications. Verify correct power is applied Verify the ribbon cable between the upper and lower circuit boards is solidly connected and the red stripe is on pin 1.
No Display or Dim Display	Adjust pot R1 on the upper left of the top circuit board. If there is no change in the display return the pot to the original setting.
Display is Locked Up	Press HOME and then 1 to return to normal operation. Reset the instrument by cycling the power.
Readings Seem Incorrect	Verify the serial number of the flow element and the flow transmitter are the same serial number. Verify the flat on the flow element is parallel to the pipe and the flow flow arrow is pointed in the direction of the flow stream. Verify the sensor is mounted in the center of the pipe. Verify the calibration data sheet matches the process configuration. Verify all jacks and plugs are all firmly seated and the wiring to them is correct and secure.

If there are still problems with the instrument, see the Troubleshooting Section in the GF Series Manual, Document Number 06EN003229. To acquire a manual call your local FCI sales representative.

Notice of Proprietary Rights

This document contains confidential technical data, including trade secrets and proprietary information which are the property of Fluid Components Intl (FCI). Disclosure of this data to you is expressly conditioned upon your assent that its use is limited to use within your company only (and does not include manufacture or processing uses). Any other use is strictly prohibited without the prior written consent of FCI.

Visit FCI on the Worldwide Web: www.fluidcomponents.com

1755 La Costa Meadows Drive, San Marcos, California 92069 USA - 760-744-6950 - 800-854-1993 - Fax 760-736-6250

European Office: Persephonestraat 3-01 5047 TT Tilburg - The Netherlands - Phone 31-13-5159989 - Fax 31-13-5799036

© Copyright 2001 Fluid Components Intl a limited liability company All Rights Reserved