

NuFlo™

2-inch Gas Flowmeter

User Manual



© **2004 NuFlo Technologies, Inc.** All information contained in this publication is confidential and proprietary property of NuFlo Technologies, Inc. Any reproduction or use of these instructions, drawings, or photographs without the express written permission of an officer of NuFlo Technologies, Inc. is forbidden.

All Rights Reserved.
Printed in the United States of America.

Manual No. 100079591NX
January 2004

Table of Contents

Nomenclature	ii
Section 1—Introduction	1
Operating Principles	1
Section 2—Setup and Calibration	5
Installation	5
Calibration	5
Absolute Pressure and Temperature	6
Calculating Gas Volume in Actual Cubic Feet	6
Calculating Gas Volume in Standard Cubic Feet	7
Determining the Divisor for Readout in Standard Cubic Feet	7
Effects of Supercompressibility	8
Calibrating Equipment for Readout in Standard Cubic Feet Per Unit of Time	8
Effects of Fluctuating Temperatures	9
Effects of Fluctuating Pressures	10
Section 3—Maintenance	15
Removing and Replacing Cartridges	15
Flowmeter Assemblies	16
Spare Parts	16
Accessories	16

Nomenclature

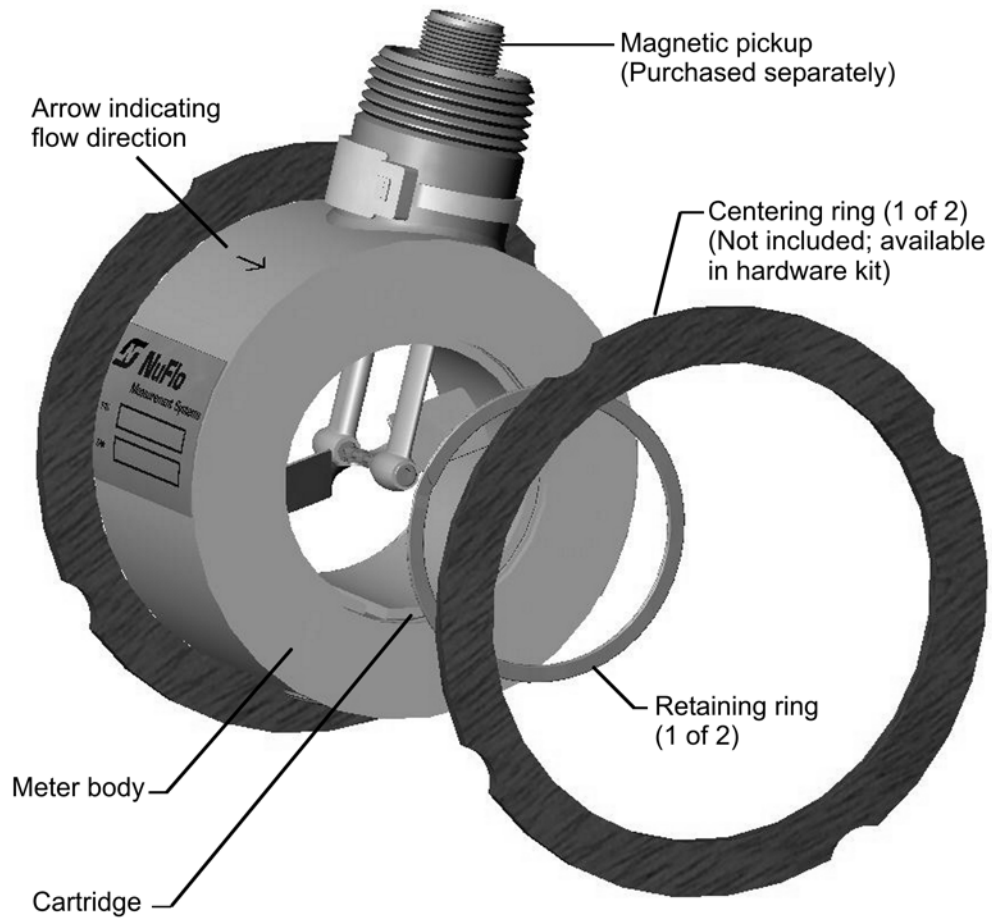

Introduction

The NuFlo 2-in. Gas Flowmeter is a turbine flowmeter, housed inside an insert element that is placed between two raised-face flanges. Continuous stud bolts draw the flanges together against the housing element, and gaskets on the face of the flanges and meter body help ensure a competent seal.

All internal components—the rotor and shaft assembly, bearings, and setscrews—are contained within a cartridge inside the meter. Three different cartridges are available to accommodate high, standard and low flow ranges (see Figs. 1.1 through 1.3).

An electromagnetic pickup screwed into the receptacle on the side of the meter produces the output signal.

Operating Principles

The gas to be measured is flowed through the meter. As the gas passes the rotor, it impinges against the pitched rotor blade, causing the rotor to spin at a speed directly proportional to the velocity of the gas stream. As the rotor spins, its blades interrupt the magnetic field set up by the pickup. This interruption induces a voltage in the coil of the pickup. The readout instrument senses this voltage pulse and converts it into a usable form that indicates gas volume.

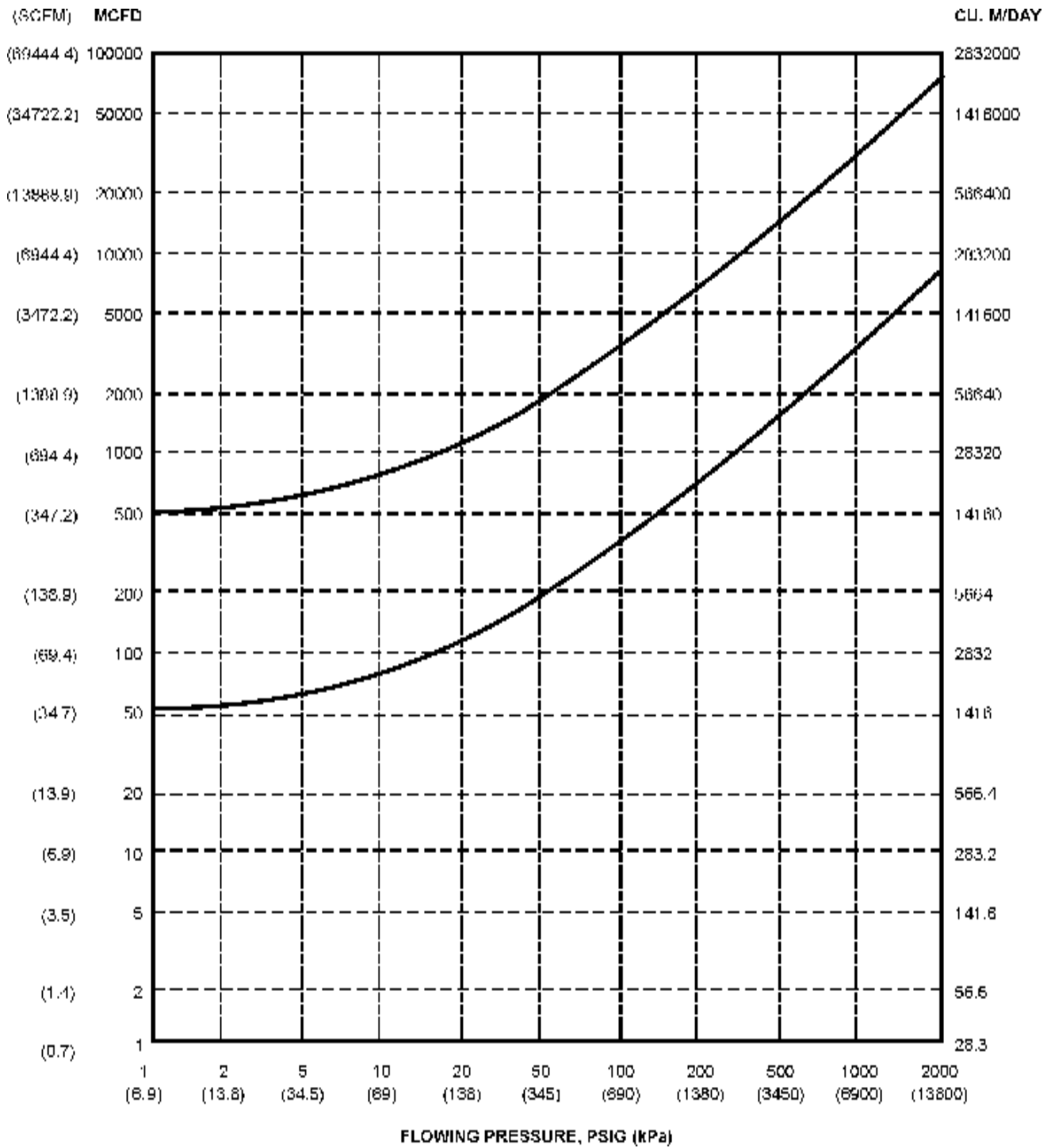

Flow rate ranges are based on 0.6 Sp. Gr. gas.
 To determine capacity for other gases, use:

$$Q_{(g)} = Q_{(.6)} \sqrt{\frac{0.6}{G}}$$

where

$Q_{(.6)}$ = Flow rate on graph at operating pressure

G = Sp. Gr. of other gas

$Q_{(g)}$ = Flow rate for other gas

Figure 1.1—High gas flow range

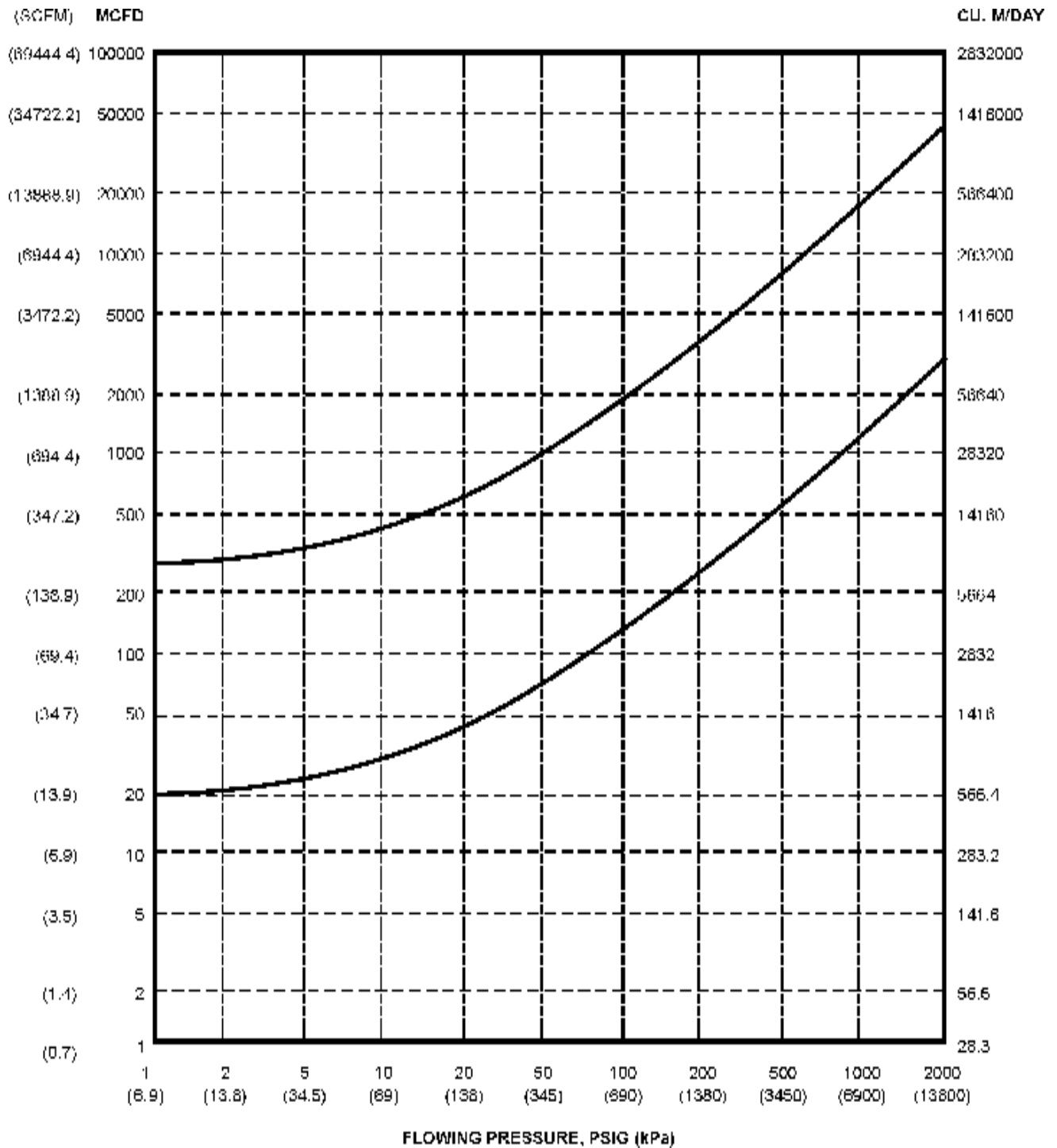

Flow rate ranges are based on 0.6 Sp. Gr. gas.

To determine capacity for other gases, use:

$$Q_{(g)} = Q_{(.6)} \sqrt{\frac{0.6}{G}}$$

where

$Q_{(.6)}$ = Flow rate on graph at operating pressure

G = Sp. Gr. of other gas

$Q_{(g)}$ = Flow rate for other gas

Figure 1.2—Standard gas flow range

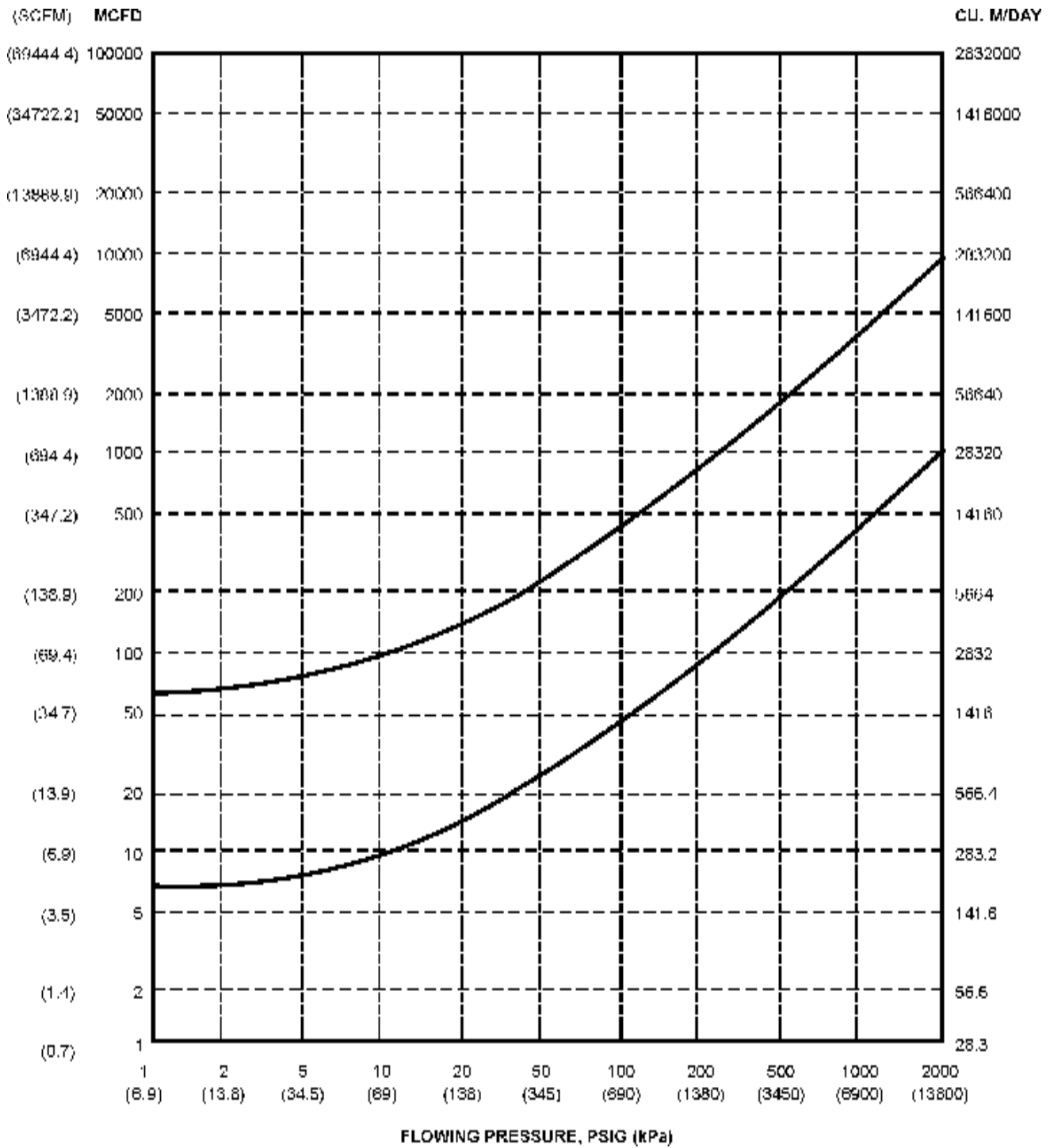

Flow rate ranges are based on 0.6 Sp. Gr. gas.
 To determine capacity for other gases, use:

$$Q_{(g)} = Q_{(.6)} \sqrt{\frac{0.6}{G}}$$

where

$Q_{(.6)}$ = Flow rate on graph at operating pressure

G = Sp. Gr. of other gas

$Q_{(g)}$ = Flow rate for other gas

Figure 1.3—Low gas flow range

Setup and Calibration

Installation

The NuFlo Gas Flowmeter must be installed properly to prevent gas from swirling or experiencing other erratic flow characteristics. Figure 2.1 shows the proper installation of the meter.

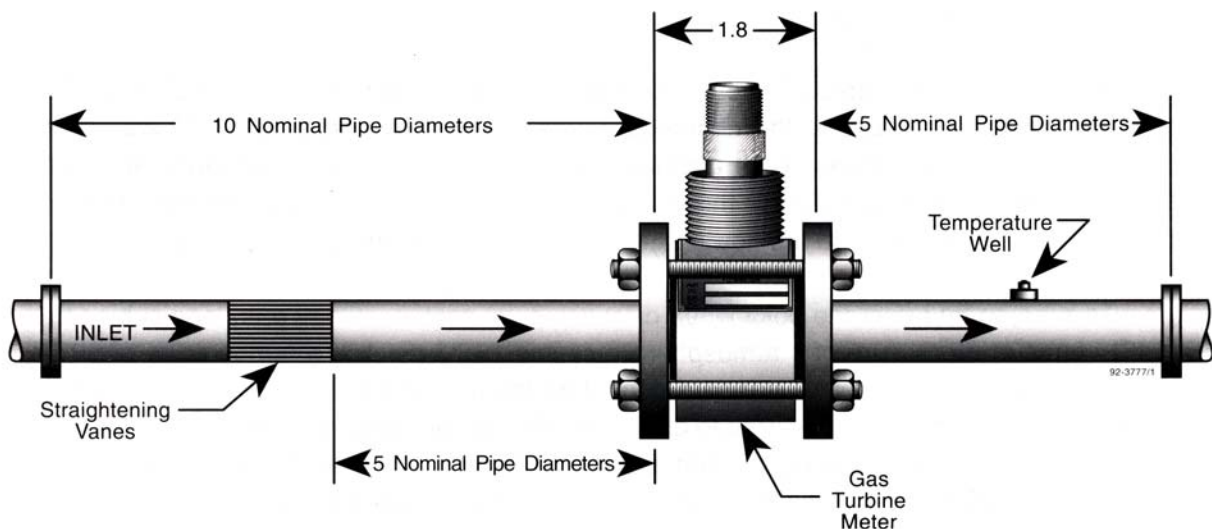

Figure 2.1—Proper installation of an in-line gas turbine meter (minimum lengths). Upstream and downstream sections are available in Schedule 40 and Schedule 80 pipe.

Calibration of Electronic Readout Equipment

Before a flowmeter leaves the factory, it is calibrated at multiple points within the flow range of the cartridge; the factor is given in pulses per actual cubic foot (acf). This factor, which is recorded on a calibration tag that is attached to the meter, is then used to calibrate electronic readout equipment in the field.

Fluid measured by the gas turbine meter is compressible, and is also affected by temperature changes. The volumetric change caused by temperature and/or pressure for any ideal gas follows the equation below:

$$\frac{P_1 V_1}{T_1} = \frac{P_2 V_2}{T_2}$$

Absolute Pressure and Temperature

The equation above shows that the volume of gas is determined by pressure and temperature. In this equation, the pressure, P, is *absolute pressure* (the flowing or observed gauge pressure plus the atmospheric pressure). The commonly used unit of measure for absolute pressure is pounds per square inch absolute (psia). For this purpose, atmospheric pressure is considered to be 14.73 psi. Therefore,

$$\text{Absolute pressure (psia)} = \text{Observed gauge pressure (psig)} + 14.73 \text{ psi}$$

The *absolute temperature* in the equation above is expressed in degrees Rankine, which is calculated as follows:

$$\text{Degrees Rankine} = \text{Flowing gas temperature (}^\circ\text{F)} + 459.67$$

Calculating Gas Volume in Actual Cubic Feet

As a point of reference for discussing volumetric units of gas, one cubic foot (1ft³) of gas at a pressure of 1 atmosphere (assume 14.73 psia) at a temperature of 60°F (519.69°R) is considered one *standard cubic foot* (scf). A cubic foot of gas at any other pressure and temperature is referred to as an *actual cubic foot* (acf) and has no significance unless the conditions of pressure and temperature are known. For example, given 1 acf of gas at 200 psig at 100°F, the volume of gas at standard conditions may be calculated with the following formula:

$$\frac{\text{standard pressure} \times \text{volume}}{\text{standard temperature}} = \frac{\text{observed pressure} \times 1 \text{ ft}^3}{\text{observed temperature}}$$

$$\frac{14.73 \times \text{volume}}{519.67} = \frac{(200 + 14.73) \times 1 \text{ ft}^3}{(100 + 459.67)}$$

$$\text{Volume} = \frac{214.73 \times 519.67}{559.67 \times 14.73}$$

$$\text{Volume} = 13.536 \text{ ft}^3$$

Therefore, 1 ft³ of gas at 200 psi and 100°F would occupy a volume of 13.536 ft³ if the pressure and temperature were reduced to standard conditions of 0 psi (14.73 psia) and 60°F. Numerous laboratory tests have shown that the NuFlo Gas Flowmeter produces the same number of pulses per actual cubic foot of gas regardless of the pressure and temperature of the gas when operated within its rated range. As a result, the calibration factor can be specified in pulses per actual cubic foot. If the readout equipment for a gas meter and the totalizer register in actual cubic feet, the flow totalizer divisor is set to the nearest whole number to the calibration factor. The counter will then register actual cubic feet, regardless of the flowing pressure and temperature.

Example: Assume a 2-in. gas flowmeter with a calibration factor of 124.96 pulses per actual cubic foot, a flowline pressure of 70 psig, and a temperature of 80°F.

If the readout equipment divisor is set for 125, totalizer measurements will be in actual cubic feet; if the readout equipment divisor is set for 1,250, totalizer measurements will be in *tens* of actual cubic feet.

Calculating Gas Volume in Standard Cubic Feet

Generally, gas is measured in standard cubic feet rather than actual cubic feet. Remember, at standard conditions (0 psi and 60°F), standard cubic feet and actual cubic feet are equivalent.

To convert actual cubic feet to standard cubic feet, use the following formula:

$$\text{Standard Cubic Feet} = \frac{\text{Actual Cubic Feet} \times P_f \times T_s}{P_s \times T_f}$$

where

P_f = flow pressure (psia)

P_s = standard pressure (14.73 psia)

T_f = flowing temperature (°R)

T_s = standard temperature (519.67°R)

Example How many standard cubic feet are in each actual cubic foot at a flowing pressure of 70 psig and a flowing temperature of 80°F?

$$\text{Standard Cubic Feet} = \frac{1.0 \times (70 + 14.73) \times 519.67}{14.73 \times (80 + 459.67)} = 5.539$$

The example above shows that there are 5.539 scf in every actual cubic foot at the flowing conditions of 70 psi at 80°F. The number of standard cubic feet may be obtained by setting the flow totalizer for the calibration factor of the gas meter as previously described, and multiplying the registration by 5.539.

Example A 2-in. gas turbine flowmeter with a calibration factor of 124.36 pulses per actual cubic foot is installed in a flowline operating at 70 psig at 80°F. The flow totalizer divisor is set at 1,244 for registration in tens of actual cubic feet. Assume that during a 24-hour period, the totalizer registers 2,327 counts. How many standard cubic feet were metered during this period?

$$\text{Standard cubic feet} = 2327 \times 10 \times 5.539 = 128,893$$

Determining the Divisor for Readout in Standard Cubic Feet

If the flowing conditions are kept constant, the multiplier for converting actual cubic feet to standard cubic feet will also remain constant. To simplify operations, consider this when computing the divisor for the readout equipment and provide a direct readout in standard cubic feet. The following formula can be used to determine the divisor for any given set of operating conditions:

$$\text{Divisor} = \frac{\text{FCF} \times P_s \times T_f}{P_f \times T_s}$$

where

FCF = flowmeter calibration factor (pulses/acf)

P_s = standard pressure (14.73 psia)

P_f = flowing pressure (psia)

T_f = flowing temperature ($^{\circ}$ R)

T_s = standard temperature (519.67 $^{\circ}$ R)

Example A 2-in. gas turbine meter has a calibration factor of 124.36 pulses per actual cubic foot, and is installed in a flowline operating at 70 psi at 80 $^{\circ}$ F. Calculate the divisor for a flow totalizer to register in standard cubic feet.

$$\text{Divisor} = \frac{124.36 \times 14.73 \times (80 + 459.67)}{(70 + 14.73) \times 519.67} = 22.452$$

A divisor of 224 should be used for readings in tens of standard cubic feet, a divisor of 2,245 should be used for readings in hundreds of standard cubic feet.

Effects of Supercompressibility

The procedures described in this manual are applicable only when the flowing pressure and temperature remain constant at the values used in the computation. If an application has a line pressure greater than 200 psig, the operator should consider the effects of supercompressibility and adjust the divisor accordingly.

The equation for calculating a divisor that allows for supercompressibility is

$$\text{Divisor} = \frac{\text{FCF} \times P_s \times T_f}{P_f \times T_s \times (F_{pv})^2}$$

where F_{pv} = supercompressibility factor

Calibrating Equipment for Readout in Standard Cubic Feet Per Unit of Time

The readout equipment's flow rate indicator and/or analog rate output may also be calibrated for the flowing conditions to provide registration in standard cubic feet per unit of time.

The rate indicator will produce the full-scale output selected when the gas turbine meter generates the frequency corresponding to that output. The following formula may be used to calculate the full-scale frequency for any particular readout device:

$$\text{FSF} = \frac{\text{FSFR} \times \text{FCF} \times P_s \times T_f}{\text{TBCF} \times P_f \times T_s}$$

where

FSF = full-scale frequency (Hz)

FSFR = full-scale flow rate (scf/unit time)

FCF = flowmeter calibration factor (pulses/acf)

P_s = standard pressure (14.73 psia)

T_f = flowing temperature (°R)

TBCF = time-based conversion factor (seconds/unit time)

P_f = flowing pressure (psia)

T_s = standard temperature (519.67°R)

Example Calculate the full-scale frequency for the readout in the previous example if the full-scale flow rate is 1,500 Mscf/D.

$$FSF = \frac{1,500,000 \times 124.36 \times 14.73 \times (80 + 459.67)}{\frac{24 \text{ hr}}{\text{day}} \times \frac{60 \text{ min}}{\text{hr}} \times \frac{60 \text{ sec}}{\text{min}} \times (70 + 14.73) \times 519.67} = 389.78 \text{ Hz}$$

The readout device should indicate 1500 Mscf/D flow with a 389.78 Hz signal fed into the flowmeter signal input.

Effects of Fluctuating Temperatures

In some applications, temperature does not remain constant and the operator must determine to what degree changing temperatures affect readout accuracy. In many cases, changes in temperature will not produce serious measurement errors and can often be ignored. However, where temperature changes are more extreme, the user may recalibrate the readout equipment seasonally to offset the impact of wide ranges of temperature changes from summer to winter.

Figure 2.2 illustrates how fluctuations in flowing temperature cause errors in standard cubic feet.

To determine the effect of temperature changes on readout accuracy, see the example below.

A 2-in. gas turbine flowmeter is installed in a flowline operating at 70 psig at 80°F. At standard conditions, 1 ft³ of gas will occupy 5.539 ft³. Determine the effects of a 10% change in temperature.

10% of 80° = 8°; therefore, the maximum temperature is 88°F and the minimum temperature is 72°F.

At 88°F,

$$\text{Standard Cubic Feet} = \frac{1.0 \times (70 + 14.73) \times 519.67}{14.73 \times (88 + 459.67)} = 5.458$$

At 72°F,

$$\text{Standard Cubic Feet} = \frac{1.0 \times (70 + 14.73) \times 519.67}{14.73 \times (72 + 459.67)} = 5.622$$

At 80°F, each actual cubic foot equaled 5.539 scf. The percentage of change caused by increasing the flow temperature to 88°F is shown below:

$$\% \text{ Change} = \frac{5.539 - 5.458}{5.539} \times 100 = -1.46 \%$$

The percentage of change caused by decreasing the flow temperature to 72°F is shown below:

$$\% \text{ Change} = \frac{5.622 - 5.539}{5.539} \times 100 = 1.50 \%$$

Effects of Fluctuating Pressures

In some applications, pressure does not remain constant and the operator must determine to what degree changing pressures affect readout accuracy. Small changes in pressure can produce large errors in standard cubic feet, especially at low flowing temperatures. Figure 2.3 illustrates the effect of fluctuations in flowing pressure on standard cubic feet. Note how the effect of changing pressure is much greater than the effect of changing temperature. The overall effect of changing temperature and pressure is the algebraic sum of the individual effects.

To determine the effect of pressure changes on readout accuracy, see the example below.

Example A 2-in. gas turbine flowmeter is installed in a flowline operating at 70 psig at 80°F. At standard conditions, 1 ft³ of gas will occupy 5.539 ft³. Determine the effects of a 10% change in temperature.

10% of 70 psig is 7 psig; therefore, the maximum pressure is 77 psig and the minimum pressure is 63 psig.

At 63 psig,

$$\text{Standard Cubic Feet} = \frac{1.0 \times (63 + 14.73) \times 519.67}{(80 + 459.67) \times 14.73} = 5.081$$

At 77 psig,

$$\text{Standard Cubic Feet} = \frac{1.0 \times (77 + 14.73) \times 519.67}{(80 + 459.67) \times 14.73} = 6.000$$

At 70 psig, each actual cubic foot equals 5.539 scf.

The percentage of change caused by reducing the flowing pressure to 63 psig is shown below:

$$\% \text{ Change} = \frac{5.081 - 5.539}{5.539} \times 100 = -8.27 \%$$

The percentage of change caused by increasing the flowing temperature to 77 psig is shown below:

$$\% \text{ Change} = \frac{6.000 - 5.539}{5.539} \times 100 = 8.32 \%$$

When faced with varying flowing pressures, consider the following alternatives:

1. Sense the pressure on the flowline and correct the output from the flowmeter.
2. Control the pressure to hold it constant within the limits of error that can be tolerated.

Alternative No. 1 requires a pressure-compensated readout, or the use of a computer that can receive a signal representing pressure and compensate for the flowmeter signal.

Alternative No. 2 is normally the least expensive since it requires only the installation of a pressure regulator in the flowline downstream of the flowmeter.

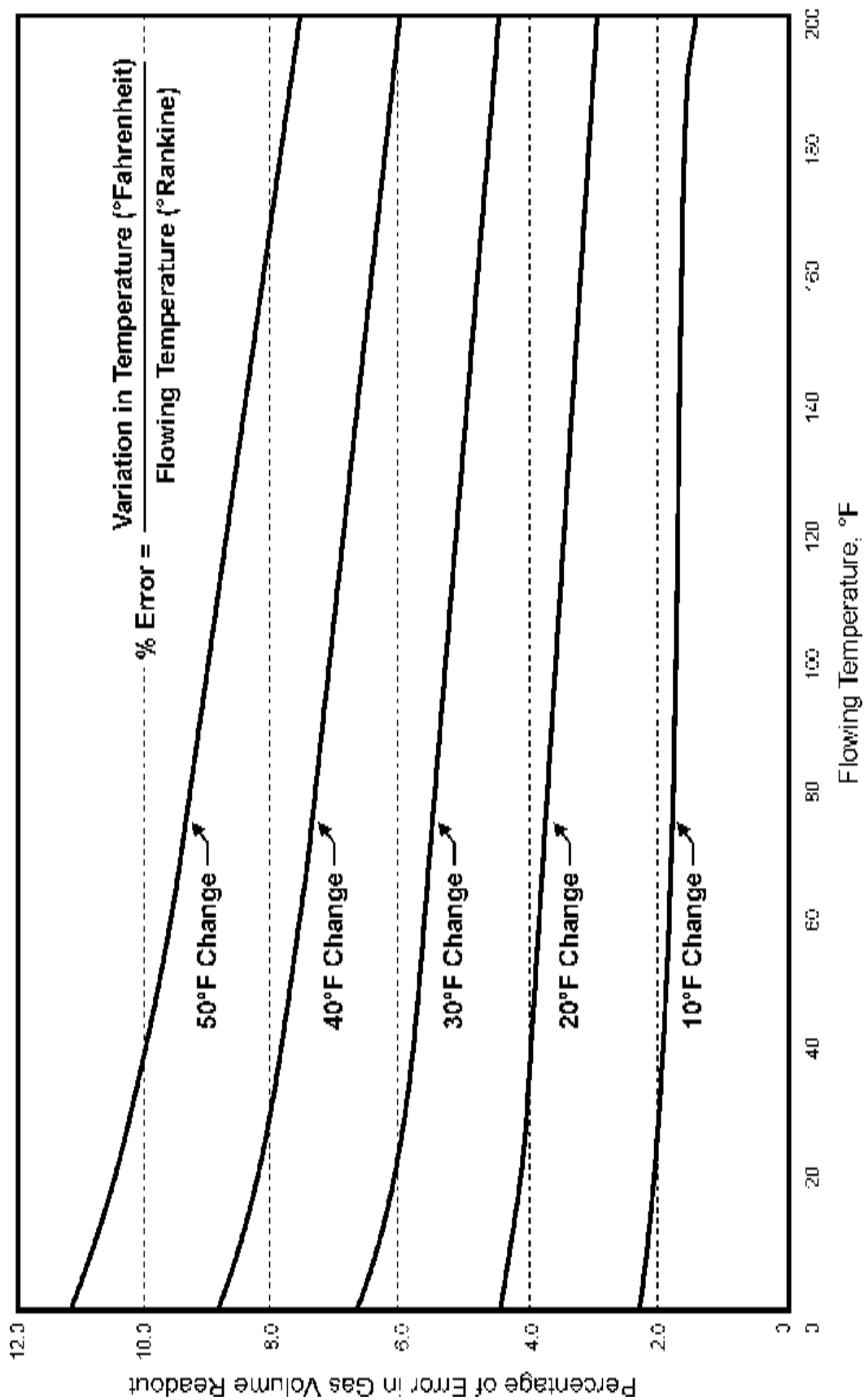

Figure 2.2—Effect of change in temperature on gas volume measurements. Positive and negative changes in temperature produce virtually the same error.

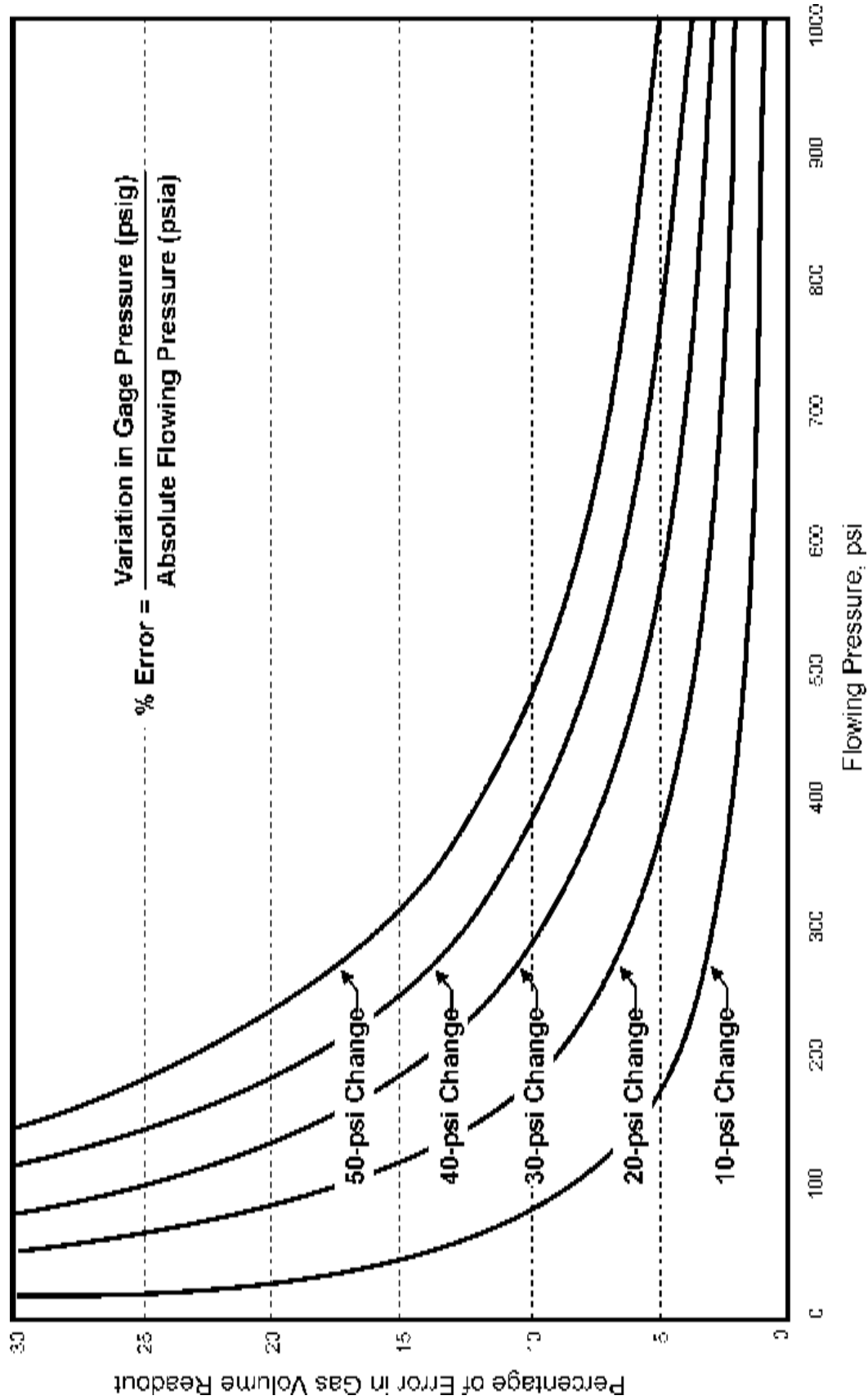

Figure 2.3—Effect of change in pressure on gas volume measurements. Positive and negative changes in pressure produce virtually the same error.

Maintenance

Because all internal components of the 2-in. gas flowmeter are contained within a cartridge, maintenance of this instrument is minimal. Should a flowmeter fail, the internal cartridge can be easily and quickly replaced in the field. See the following procedure for removing and replacing cartridges. See Tables 3.1 through 3.3 for ordering information.

Removing and Replacing Cartridges

IMPORTANT—Never disassemble or adjust a cartridge before installing it. Each cartridge is precalibrated as a unit at the factory.

To replace a gas flowmeter cartridge, perform the following steps:

1. Remove the meter from the flowline.
2. Remove the magnetic pickup.
3. Remove the retainer rings from each end of the housing.
4. Press the cartridge out from either end of the housing.

IMPORTANT—Do not press on the struts; they may bend.

5. Locate the point next to the hole in the top of the new cartridge. This point indicates flow direction.
6. Position the new cartridge so that the flow direction indicated on the cartridge matches the flow direction indicated by the arrow on the flowmeter housing.
7. Snap the cartridge into place, taking care to apply pressure only to the outer diameter of the cartridge.
8. Rotate the cartridge until the hole in the top lines up with the threaded hole in the housing used to attach the magnetic pickup.
9. Install retainer rings into each end of the housing.
10. Replace the magnetic pickup by screwing it in hand-tight and securing the jam nut. **DO NOT OVERTIGHTEN.**
11. Replace the flowmeter in the flowline, ensuring that the flow direction arrow points in the proper direction.
12. For positive factor identification, wrap the strap of the plastic tag bearing the factor around the conduit adapter, thread the end of the strap through the hole in the tag and pull tight. Cut off excess strap length.

Flowmeter Assemblies

The 2-in. gas flowmeter assembly is available in three different styles to accommodate standard, high, and low flow rates. See Table 3.1 below for the part numbers for these assemblies.

Table 3.1—Gas Flowmeter Assemblies

Part Number	Description
100003397	Gas meter assembly, low flow range
100003398	Gas meter assembly, standard flow range
100003399	Gas meter assembly, high flow range

Spare Parts

The following spare parts are recommended for use with the NuFlo 2-in. Gas Flowmeter.

Table 3.2—Spare Parts

Item	Part Number	Qty.	Description
1	100003517	1	Cartridge, rotor assembly (standard range)
1a	100005113	1	Cartridge, rotor assembly (low range)
1b	100005134	1	Cartridge, rotor assembly (high range)
2	100003518	1	Pickup - magnetic
3	100062541	2	Centering ring
4	100005137	1	Pickup adapter extensions (required with use of 300, 600, and 900 ANSI flanges)
5	100020977	2	Ring – retaining

Accessories

The following accessories are available for use with the NuFlo 2-in. Gas Flowmeter.

Table 3.3—Accessories (Optional)

Part Number	Description
50336500100	2-in., Sch. 40 1100L carbon steel line type vane
50336500101	2-in., Sch. 80 1100L carbon steel line type vane
50336500104	2-in., Sch. 40 1106L 316SS line type vane
50336500105	2-in., Sch. 80 1106L 316SS line type vane

WARRANTY - LIMITATION OF LIABILITY: Seller warrants only title to the products, software, supplies and materials and that, except as to software, the same are free from defects in workmanship and materials for a period of one (1) year from the date of delivery. Seller does not warranty that software is free from error or that software will run in an uninterrupted fashion. Seller provides all software "as is". THERE ARE NO WARRANTIES, EXPRESS OR IMPLIED, OF MERCHANTABILITY, FITNESS OR OTHERWISE WHICH EXTEND BEYOND THOSE STATED IN THE IMMEDIATELY PRECEDING SENTENCE. Seller's liability and Buyer's exclusive remedy in any case of action (whether in contract, tort, breach of warranty or otherwise) arising out of the sale or use of any products, software, supplies, or materials is expressly limited to the replacement of such products, software, supplies, or materials on their return to Seller or, at Seller's option, to the allowance to the customer of credit for the cost of such items. In no event shall Seller be liable for special, incidental, indirect, punitive or consequential damages. Seller does not warrant in any way products, software, supplies and materials not manufactured by Seller, and such will be sold only with the warranties that are given by the manufacturer thereof. Seller will pass only through to its purchaser of such items the warranty granted to it by the manufacturer.



NuFlo
Measurement Systems

NuFlo Measurement Systems
14450 John F. Kennedy Blvd.
Houston, TX 77032
www.nuflotech.com

North America:

800-654-3760

281-582-9500 (Houston)

877-891-6540 (Calgary)

UK:

44-1243-826741

Singapore:

65-6737-0444