



June 2004
224-790-00A

*Programmable Current/Voltage
Limit Alarm Trips*

SPA²

HLPRG

SPA²

*Programmable Current/Voltage
Limit Alarm Trips*



SPA² (HLPRG) Quickstart Guide

Use the front pushbuttons to quickly and easily set-up the SPA² for your application. After programming your alarm using the diagram below, install the unit into your application using the connection diagrams and terminal designation table located in this manual.

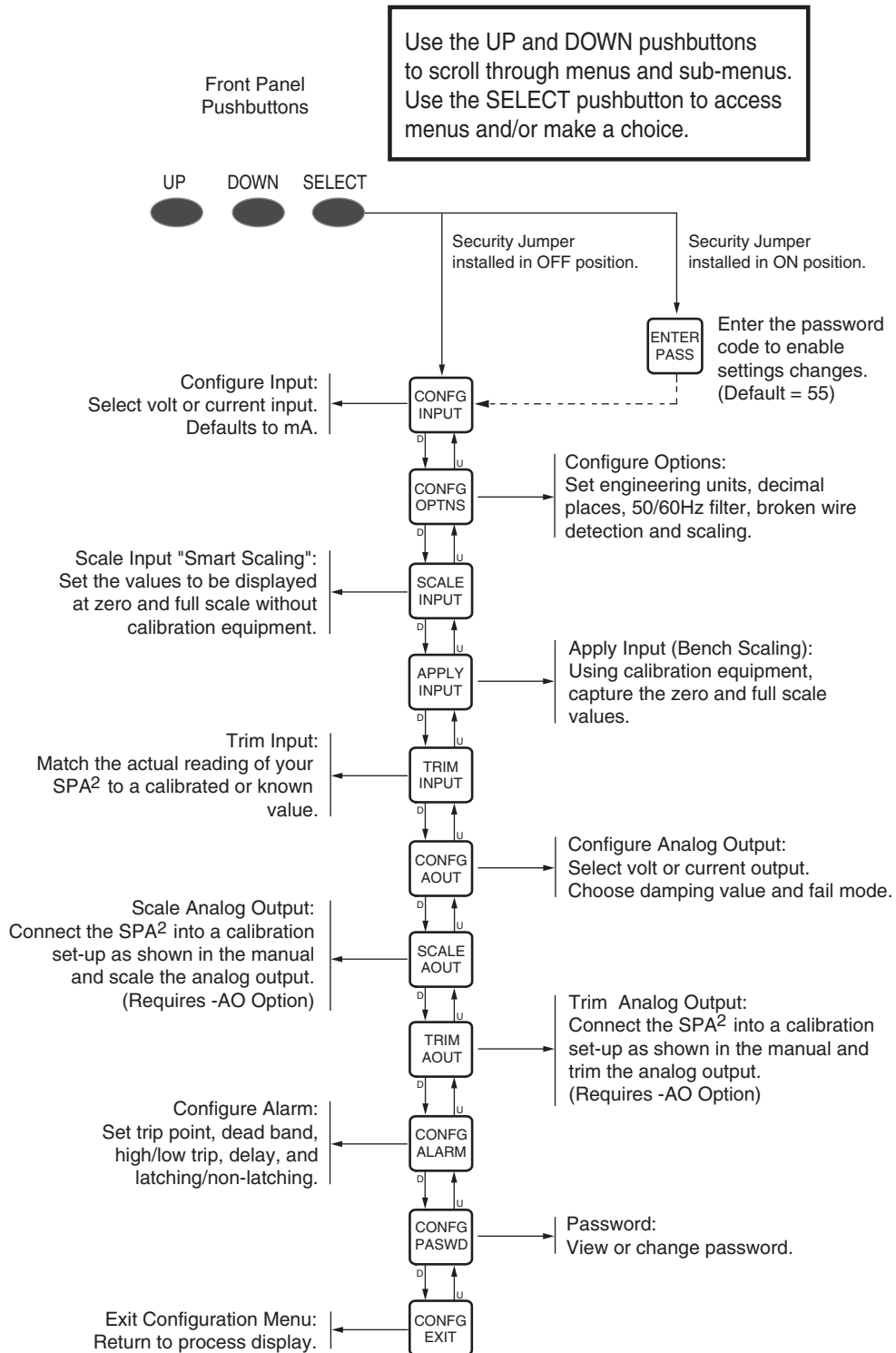

Table of Contents

Introduction	5
About This Manual	5
Model and Serial Numbers	5
Inputs	5
Outputs	5
Options	5
Internal Settings	5
Specifications	6
Dimensions	7
SPA² Configuration: Front Panel Pushbuttons	10
Main Menu/View Menu	10
Password	10
Configuring the Input	13
Configuring the Options	14
Scaling the Input	16
Applying Input (Bench Scaling)	17
Input Trimming	17
Configuring the Analog Output (-AO Option)	19
Scaling the Analog Output (-AO Option)	20
Trimming the Analog Output (-AO Option)	21
Configuring the Alarm(s)	23
Password Configuration	29

SPA² Configuration: PC Configuration Software	30
Installing the Configuration Software	30
Connecting the SPA ² to the PC	30
PC Configuration Software Summary	32
Status and Tool Bar Legend	33
Configuration Screens	33
Input	33
Display	34
Alarms	35
Analog Output	37
Scaling	40
Custom Curve	40
Error Codes	42
Installation	43
Mounting	43
Making the Electrical Connections	43
Recommended Gound Wiring Practices	43
CE Conformity	43
Operation	43
Maintenance	43
Customer Support	43

Introduction

This is the user's manual for Moore Industries' SPA² (HLPRG): Programmable Current/Voltage Limit Alarm. The instrument is configured using a combination of front panel pushbuttons and a dedicated PC Configuration Program. The SPA² monitors a process variable and provides up to four, fully user-configurable contact closure outputs that can be individually programmed to trip whenever the input falls outside a user-set, high or low trip point. The SPA² is typically used to activate a warning light, bell or buzzer; or to initiate a system shutdown. Thus, the instrument acts as a simple, but highly reliable and effective means of monitoring and safe-guarding a process.

About this Manual

Wherever you see a "**Note**", "**Caution**" or "**WARNING**" pay particular attention.

WARNING - Hazardous procedure or condition that could injure the operator.

Caution - Hazardous procedure or condition that could damage or destroy the unit.

Note - Information that is helpful for a procedure, condition, or operation of the unit.

Model and Serial Numbers

Moore Industries uses a system of model and serial numbers to keep track of all of the information on every unit it sells and services. If a problem occurs with your SPA², check for a tag affixed to the unit listing these numbers. Supply the Customer Support representative with this information when calling.

Inputs

The SPA² (HLPRG) ("High Level" Programmable input), handles either current inputs from 0-50mA (1mA minimum span) or voltage inputs from 0-10V (250mV minimum span).

Outputs

Alarms

The SPA² can be ordered with two (-2PRG) or four (-4PRG) contact closure alarms. Each alarm can be individually programmed.

2PRG

This is a two relay output with 5A @ 250Vac or 24Vdc, 50/60Hz non-inductive contact rating. The contact arrangement is SPDT; however, the -2PRG output is also available in a DPDT contact arrangement. All relay contacts (NO, NC and COM) are available for use. No jumpers are required.

4PRG

This is a four relay output with 5A @ 250Vac or 24Vdc, 50/60Hz non-inductive contact rating. The contact arrangement is SPDT. All relay contacts (NO, NC and COM) are available for use. No jumpers are required.

TX Power

A transmitter excitation power supply (24Vdc $\pm 10\%$ @ 24mA) is standard on the SPA² (HLPRG). You may access this externally at the terminals shown in Figure 3.

Options

Analog Output (-AO)

The SPA² can be equipped with a scaleable output option to provide a 0-20mA or 0-10V output. -AO equipped units are set by the user to provide either current (user-configurable between source or sink) or voltage.

Internal Settings

The password security function of the SPA² is controlled by a single jumper inside the top of the unit housing. You will need to remove the top cover in order to access the jumper. Refer to Figure 2 for location and jumper settings.

SPA²

Programmable Current/Voltage
Limit Alarm Trips

Specifications

<p>Performance Alarm Trip Repeatability: Current inputs, ± 2 microamps (0.01% of 20mA span); Voltage inputs, $\pm 1\text{mV}$ (0.01% of max. span) Display Accuracy: ± 1 digit; when scaling the display (or in Custom Mode), high input-to-display span ratios decrease display accuracy Input Accuracy: Current inputs, ± 2 microamps (0.01% of 20mA span); Voltage inputs, $\pm 1\text{mV}$ (0.01% of max. span) Stability: Refer to Table 1 Dead Band: 11.5V or 50mA, maximum in Linear Mode; equivalent of maximum input range in user-set engineering units in Scaling/Custom Mode Response Time: 256msec maximum (Defined as the time from step change on input to alarm state change when alarm is set to trip at mid-point) Alarm Trip Delay: Programmable from 0-120 seconds Line Voltage Effect: $\pm 0.002\%$ of span for a 1% change in line voltage (AC or DC) Isolation: 1000Vrms between case, input, output (units with -AO option) and power, continuous. Will withstand a 1200Vac dielectric strength test for one minute (with no breakdown) WITH -RF OPTION: 500Vrms between case, input, output and power Power Supply: 24DC range, 18-30Vdc; UAC range, 90-260Vdc; 110DC range, 75-150Vdc</p>	<p>Performance (continued) Power Consumption: 3.5W max. (24DC supply); 4W max. (UAC supply); 6W max. (110DC supply) Input Impedance: Current inputs, 20ohms; Voltage inputs, 1Mohm Input Over-Range Protection: Voltage inputs, $\pm 30\text{Vdc}$ of max. input span; Current inputs, $\pm 100\text{mA}$ of max. input span</p> <p>Performance with Analog Output (-AO Option) WITH ANALOG OUTPUT Output Accuracy: Current, $\pm 0.01\%$ of max. span (± 2 microamps); Voltage, $\pm 0.01\%$ of max. span ($\pm 1\text{mV}$) Response Time: 256msec maximum (128msec typical) for the output to change from 10% to 90% of its scale for an input step change of 0 to 100% Ripple (up to 120Hz): Current output, 10mVp-p when measured across a 250ohm resistor; Voltage output, 50mVp-p max. Output Limiting: Current outputs, <table border="1" style="display: inline-table; margin-left: 20px;"> <thead> <tr> <th>Output</th> <th>Failure Limits</th> </tr> </thead> <tbody> <tr> <td>0-20mA</td> <td>0, 23.6mA</td> </tr> <tr> <td>4-20mA</td> <td>3.6, 23.6mA</td> </tr> <tr> <td>X-20mA (90% of X)</td> <td>23.6mA</td> </tr> </tbody> </table> Voltage output, -0.5-11V Load Effect (current outputs): $\pm 0.01\%$ of span from 0 to maximum load resistance on current output</p> <p>Ambient Conditions Operating Range: -40°C to +85°C (-40°F to +185°F) Relay Range: -25°C to +70°C (-13°F to +104°F) Storage Range: -40°C to +85°C (-40°F to +185°F)</p>	Output	Failure Limits	0-20mA	0, 23.6mA	4-20mA	3.6, 23.6mA	X-20mA (90% of X)	23.6mA	<p>Ambient Conditions (continued) Ambient Temperature Effect: Current, 2 microamps/°C; Voltage, 1mV/°C; Output, $\pm 0.009\%$ of max. span/°C Relative Humidity: 0-95% non-condensing RFI/EMI Protection: 80-1000MHz, 1kHz AM, when tested to IEC61326 with 0.5% of span or less error WITH -RF OPTION: 20V/m@80-1000MHz, 1kHz AM, when tested to IEC61326 with 0.5% of span or less error Noise Rejection: Common Mode, 100dB@50/60Hz Normal Mode, Current Input, 70dB typical@50mA-p-p@50/60Hz; Voltage Input, 70dB typical@1Vp-p@50/60Hz</p> <p>Adjustments Front panel pushbuttons control settings for zero, span, alarm trip points, high/low alarms, etc.; Internal jumper and menu password protect parameter settings</p> <p>Indicators LCD: 2x5 14-segment characters, backlit, alphanumeric readout accurate to the nearest digit. Range: -99999 to 99999; Decimal point can be user-set LED Type: INPUT LED: Dual color LED indicates input failure READY LED: Green LED indicates unit is operating properly ALARM 1, 2, 3 and 4 LED: Dual color LED per relay indicates alarm status</p> <p>Weight 544 g to 601 g (19.2 oz to 21.2 oz)</p>
Output	Failure Limits									
0-20mA	0, 23.6mA									
4-20mA	3.6, 23.6mA									
X-20mA (90% of X)	23.6mA									

Specifications and information subject to change without notice.

Table 1. Long-Term Stability

Stability (% of maximum span)	Input-to-Output (Years)			Input-to-Relay (Years)		
	1	3	5	1	3	5
Current Inputs	0.081	0.14	0.18	0.047	0.81	0.105
Voltage Inputs	0.093	0.16	0.21	0.066	0.114	0.147

SPA²

Programmable Current/Voltage
Limit Alarm Trips

Figure 1. SPA² (HLPRG) Dimensions

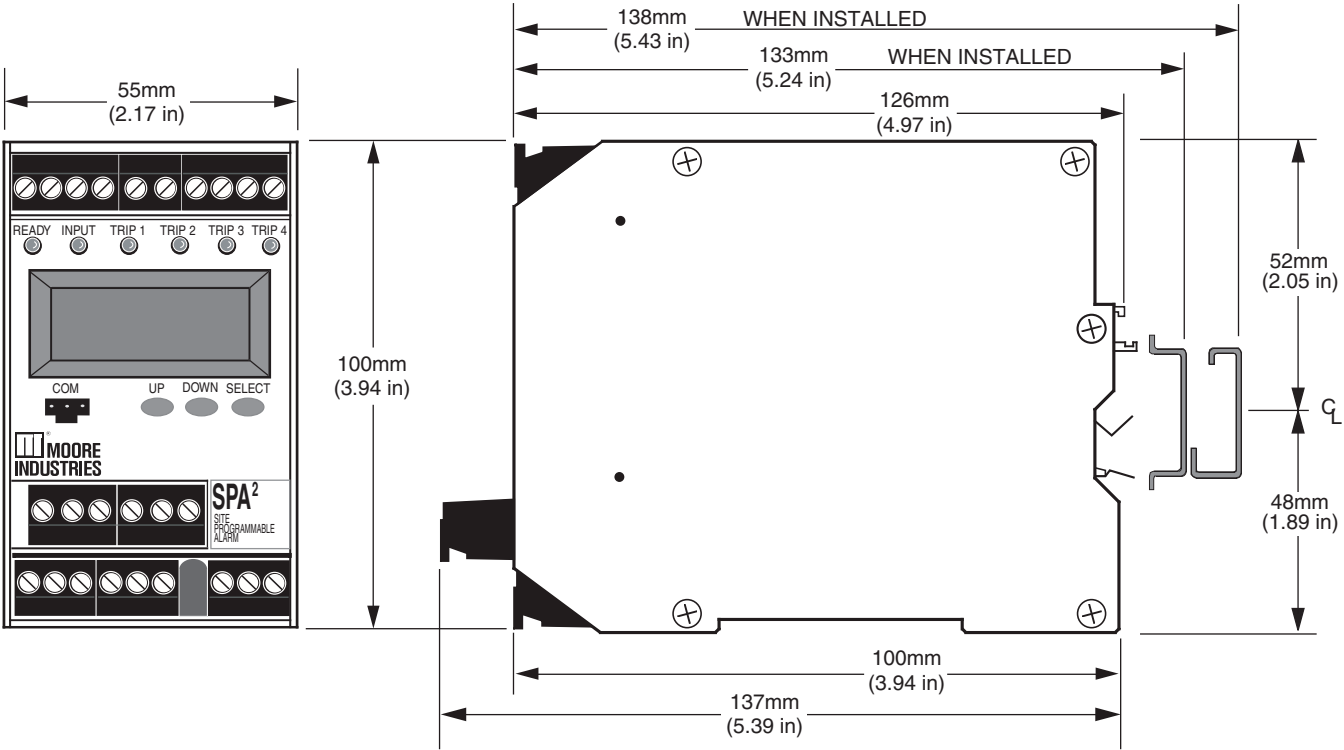
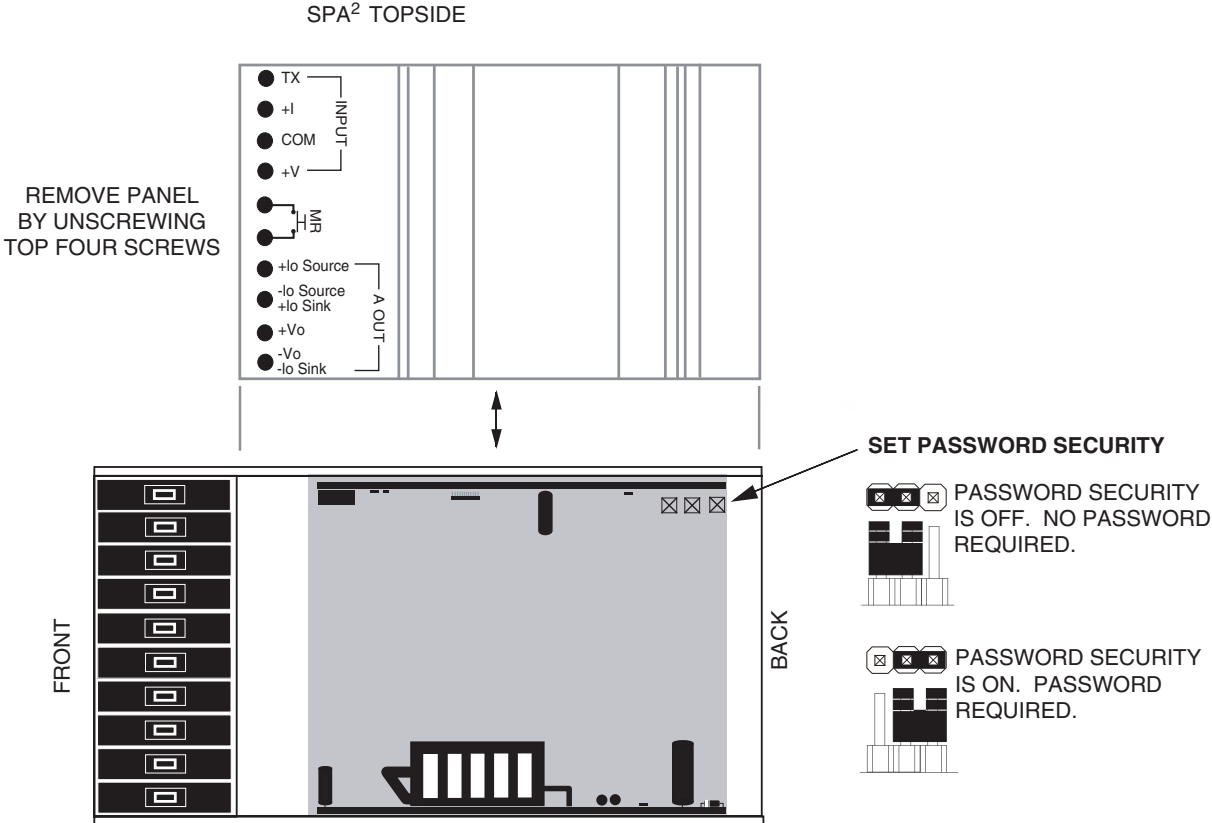

Figure 2. Setting the Internal Jumper for Password Security ON or OFF



SPA²

Programmable Current/Voltage Limit Alarm Trips

Table 2. SPA² (HLPRG) Terminal Designations

Input Type	Top Terminals (Left to Right)									
	T1	T2	T3	T4	T5	T6	T7	T8	T9	T10
Current Input	Tx	+I	COM	Not Used	MR	MR	+Io Source	-Io Source +Io Sink	+Vo	-Vo -Io Sink
Voltage Input	Tx	Not Used	COM	+V	MR	MR	+Io Source	-Io Source +Io Sink	+Vo	-Vo -Io Sink

Output Type	Middle Terminals (Left to Right)					
	11	12	13	14	15	16
2PRG (SPDT Relays)	N/A	N/A	N/A	N/A	N/A	N/A
4PRG (SPDT Relays)	NO3	CM3	NC3	NO4	CM4	NC4
2 DPDT Relays	Relay 2 NO1	Relay 2 CM1	Relay 2 NC1	Relay 2 NO2	Relay 2 CM2	Relay 2 NC2

Output/Power Type	Bottom Terminals (Left to Right)									
	B1	B2	B3	B4	B5	B6	B7	B8	B9	B10
2PRG (SPDT Relays)	NO1	CM1	NC1	NO2	CM2	NC2	Not Used	AC or DC	ACC or DCC	GND
4PRG (SPDT Relays)	NO1	CM1	NC1	NO2	CM2	NC2	Not Used	AC or DC	ACC or DCC	GND
2 DPDT Relays	Relay 1 NO1	Relay 1 CM1	Relay 1 NC1	Relay 1 NO2	Relay 1 CM2	Relay 1 NC2	Not Used	AC or DC	ACC or DCC	GND

NOTES:

- Terminal blocks can accommodate 14-22 AWG solid wiring.
- +Io/-Io/±Vo labeling is present only when the unit is equipped with the Analog Output (-AO) option.
- Your input power requirement (AC or DC / ACC or DCC) will depend upon your unit's power need.

KEY:

AC/DC = Power Input	I = Current Input	Source = Current Source
ACC/DCC = Power Input	Io = Current Output	SPDT = Single-Pole/Double-Throw
CM = Relay Common	MR = Manual Reset	TX = Power for 2-wire transmitter
COM = Analog Common	NO = Normally Open	V = Voltage Input
DPDT = Double-Pole/Double-Throw	NC = Normally Closed	Vo = Voltage Output
GND = Ground	Sink = Current Sink	

SPA²

Programmable Current/Voltage
Limit Alarm Trips

Figure 3. SPA² (HLPRG) Hook-Up Diagram For Front Panel Configuration

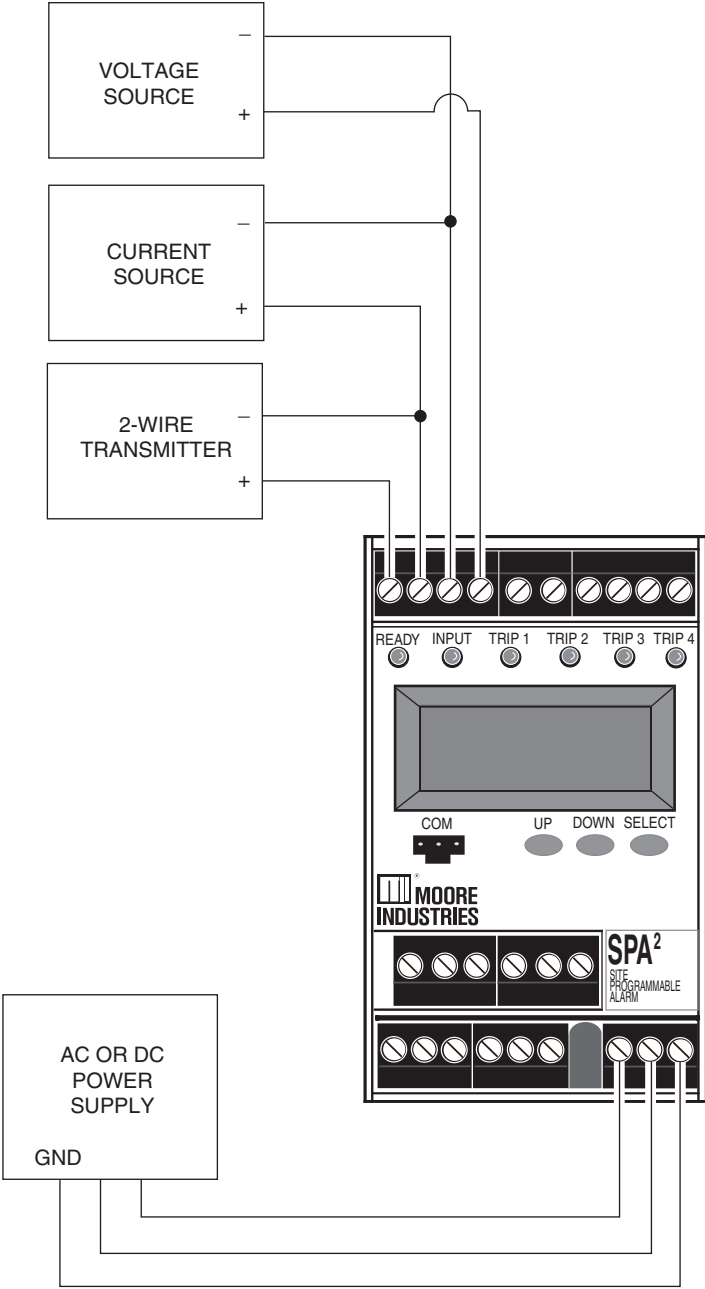

SPA²

Programmable Current/Voltage
Limit Alarm Trips

SPA² Configuration: Front Panel Pushbuttons

The SPA² (HLPRG) operating parameters may be set using front panel pushbuttons and/or Moore Industries' PC Configuration Software. This section describes configuration via the front panel pushbuttons.

There are three pushbuttons on the unit's front panel; *UP*, *DOWN* and *SELECT*. Together with the prompting messages displayed on the LCD, these are used to access menus, and to view and change the settings.

Use *SELECT* as your "Enter" button, to make your selections.

Use the *UP* and *DOWN* buttons to navigate within the menus.

Note:

All parameters, except the Custom Curve feature, can be configured using the front panel pushbuttons. The Custom Curve table can only be configured using the PC Configuration Software Program.

Main Menu/View Settings

Figure 4 gives an overview of the Main menu; the View menu is shown in Figure 5.

Upon power-up, the SPA² defaults to a display of the measured value. Pressing the *DOWN* button accesses a series of displays that show, in succession, the settings currently stored in unit memory.

Depending upon whether or not the Security Jumper has been installed (Figure 2), pressing *SELECT* will access either the first screen in the main configuration menu, "CONFIG INPUT", or the password code query screen, "ENTER PASS".

Once the Main Menu has been accessed, the *DOWN* button is used to move through all of the sub-menus in a loop. Pressing the *SELECT* button accesses the first screen of the sub-menu shown on the LCD.

Password

This menu is bypassed if the Password Security Jumper is not installed. If the jumper is installed, the menu comes up when *SELECT* is pressed from the display of the process variable input. To access the security jumpers, you must remove the top cover (refer to Figure 2). The menu is shown as part of Figure 4. Refer to the *Password Configuration* section of this manual for a more detailed description of the password feature.

1. If the jumper is installed, pressing *SELECT* from the display of the process variable input will bring up the "ENTER PASS" screen.
2. Press *SELECT* again to enter the "PASS" screen. Use the *UP* and *DOWN* buttons to enter "55", the default screen for this point in the menu.
3. If a password has been set (four characters, maximum), use the *UP* or *DOWN* buttons to display the correct password.

When the correct password number is displayed, press *SELECT*.

Note:

If the correct password is not known, the unit settings can be viewed, but not changed.

4. If you have entered the correct password, the input configuration menu, "CONFIG INPUT", will be accessed. If not, the display will show a "VIEW ONLY" message.
5. From "VIEW ONLY", press *SELECT* to go back to the process variable input. Use the *UP* and *DOWN* buttons to view the settings in the various menus. The "VIEW ONLY" mode locks out any attempt to make changes to the settings.

Note:

The menu to set or change the password stored in SPA² memory is presented in the Password Configuration section of the manual.

Figure 4. Main Menu and Password Menu

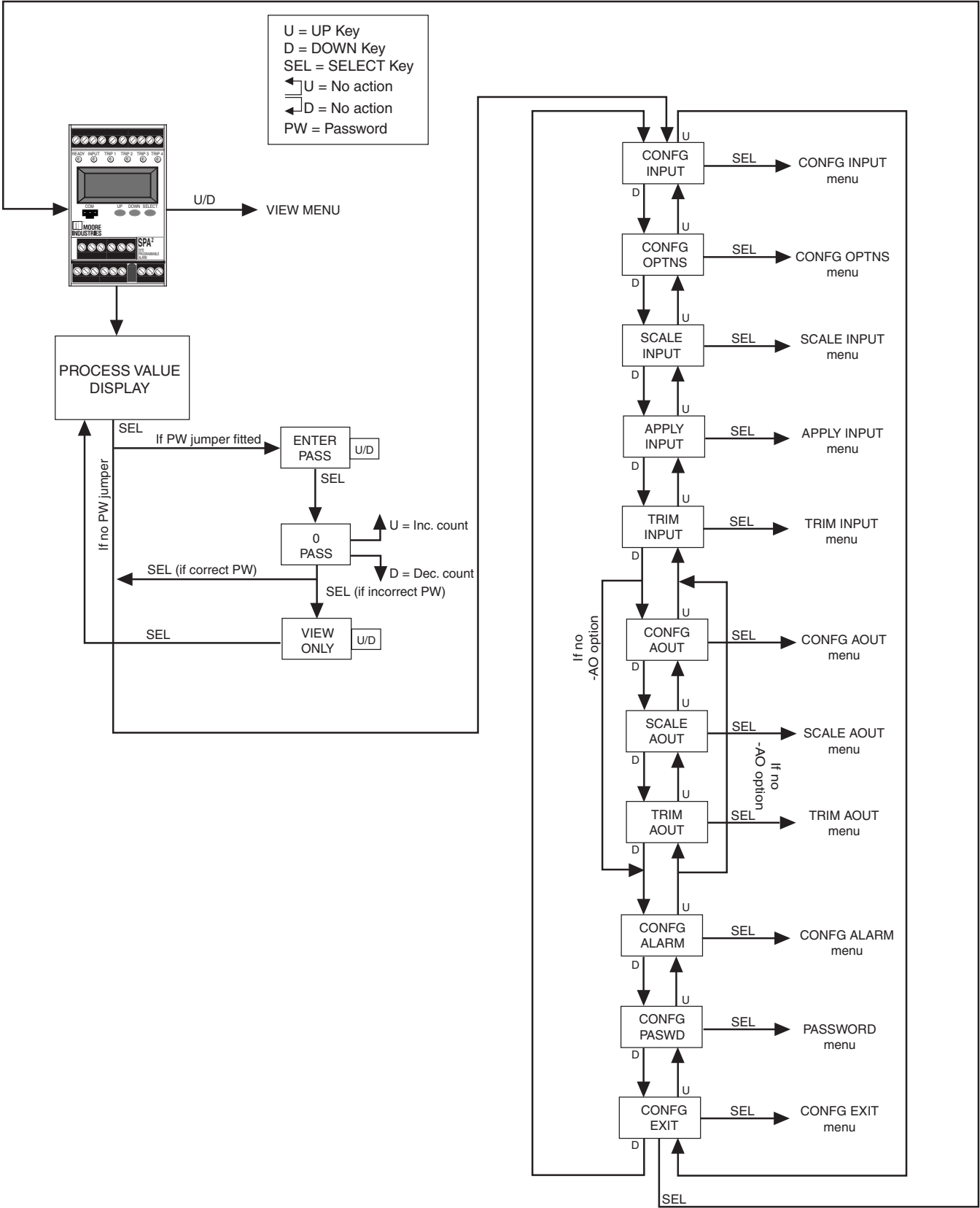

SPA²

Programmable Current/Voltage Limit Alarm Trips

Figure 5. View Menu

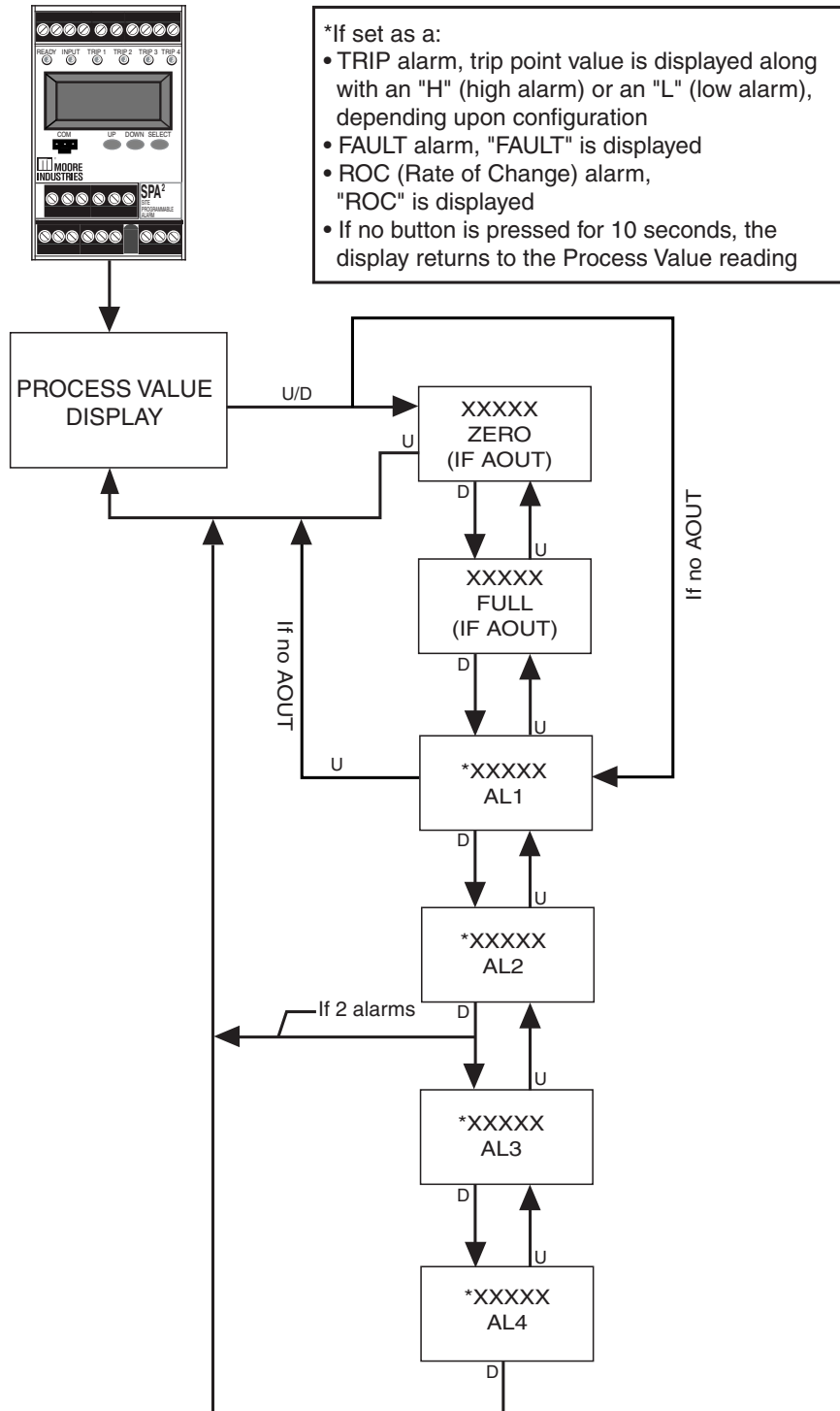

Configuring the Input

Figure 6 gives an overview of the Input Configuration menu.

If the Password Jumper is not installed, the password sub-menu is bypassed, and the "CONFIG INPUT" menu is accessed by pressing *SELECT* from the process variable display.

1. From the "CONFIG INPUT" display, press *SELECT*.
2. At "INPUT TYPE" press *SELECT*. The display shows, "CURNT" or "VOLTS" (current or voltage parameter). Use the *UP* or *DOWN* arrow buttons to scroll through the two options for input type. The default display for this menu is always the last setting.
3. When the display shows the type of input, current or voltage, that you choose to use, press *SELECT*.
4. Next, the available input values are displayed. Use the *UP* or *DOWN* buttons to scroll through the selections, choose a value that is greater than or equal to the maximum value for the input you will be monitoring and press *SELECT* when the value has been displayed.
5. "EXIT INPUT" appears. If all values in this parameter have been set, press *SELECT*. If not, return to the menu and set your values.
6. The next display is the menu for the selection of functional options, "CONFIG OPTNS". To skip the rest of the configuration menus and return to the process variable display, press the *UP* button twice (to "CONFIG EXIT"), and press *SELECT*.

Figure 6. CONFIG INPUT Menu

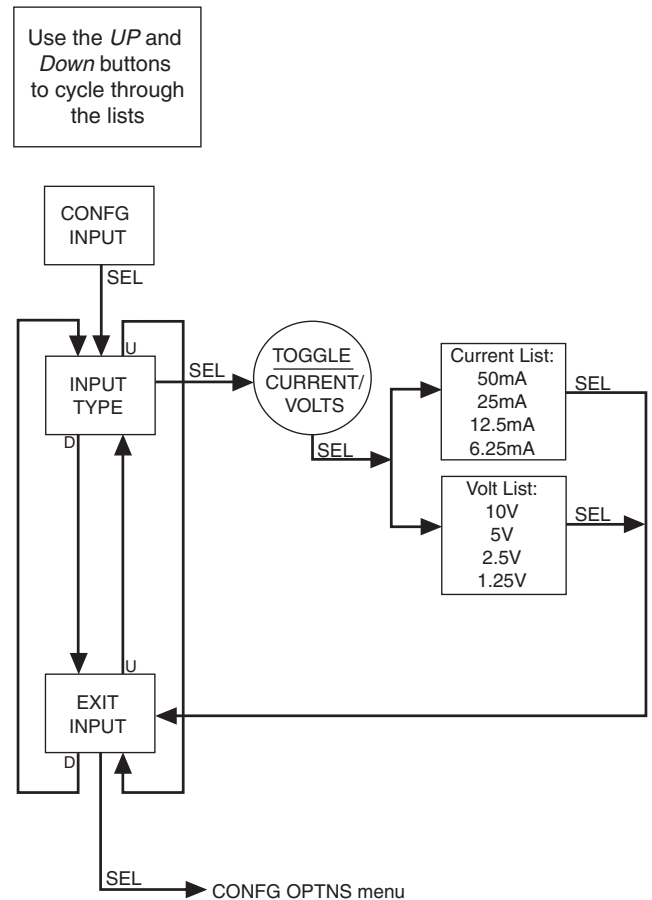

SPA²

Programmable Current/Voltage Limit Alarm Trips

Configuring the Options

Figure 7 gives an overview of the Options Configuration menu.

You may configure the process variable display, decimal places, 50/60Hz filter selection, broken wire detection and the scaling mode from this menu.

To configure the options of the the SPA²:

1. At the “CONFIG OPTNS” screen, press **SELECT**.
2. “DSPLY MODE” appears. Press **SELECT** to enter the menu. Choose between “NORM MODE” and “TOGGLE MODE” by using the **UP** and **DOWN** buttons. Press **SELECT**.
NORM MODE– Displays only your PV or AOUT value, whichever you select.
TOGGLE MODE– Every four seconds your display will toggle between two displays that you choose.
3. Next, “DSPLY SRC 1” appears. Press **SELECT** and choose between “AOUT” (if your unit is equipped with the -AO option) or “PV” by using the **UP** and **DOWN** buttons. Press **SELECT**.
If you selected “TOGGLE MODE”, you will next be asked to enter your “DSPLY SRC 2” value.
4. The “DSPLY EGU 1” prompt is brought up. Press **SELECT** and choose the desired appearance of your display. Press **SELECT**.
If you selected “TOGGLE MODE”, you will next be asked to enter your “DSPLY EGU 2” value.
5. Next, the “SET DPS” display appears. Press **SELECT**. Scroll through the available choices by using the **UP** and **DOWN** buttons and press **SELECT** once you have made your selection.
6. “SET FILTR” appears; press **SELECT**. Here, you must select the proper line frequency of your AC source—50Hz or 60Hz; press **SELECT**.
7. When “SET BWIRE” appears, press **SELECT** to enter the menu. You must choose whether or not to enable Broken Wire Detection. Press **SELECT**.

Broken Wire Detection– The SPA² monitors your process variable. If the monitored value falls equal to or below a set value, then a state of Broken Wire is declared.

Caution:

Moore Industries does not recommend use of broken wire detection if using a voltage input on the SPA². Various factors may hinder the unit’s performance and greatly slow the broken wire response time. If broken wire detection is used on a voltage input, testing must be done on a regularly scheduled basis, both with near-end and far-end open circuits on each of the wires.

Leakage current into a broken wire can prevent the voltage from dropping to the broken wire threshold. For example, on a 1-5V input, with a broken wire threshold of 0.6V, a leakage current of 1microamp into the broken wire will hold the input voltage at approximately 1.1V indefinitely. No alarm results under these conditions.

If the external wiring is long and has significant capacitance, broken wire response time is slowed by the RC time constant of the SPA² input resistance and the external wire capacitance. For example, 1 km of wire with 100pf/m capacitance and a far-end break, has a capacitance of 0.1microfarad. The time constant will be 0.11 seconds. Using a starting voltage of 3V and a broken wire threshold of 0.6V, the threshold is reached in approximately 0.18 seconds. The instrument response time must be added to this time.

If both leakage and capacitance exist, the time to threshold can extend greatly. Using a 5V starting voltage, 0.6V threshold voltage, 1 km of wire and 0.5 microamps leakage current, the threshold is reached in 0.42 seconds. The instrument response time must then be added to this time.

8. “SCALE MODE” appears; press **SELECT**. Choose whether or not to enable scaling. This will be configured in the next menu. Select “SCALE OFF” or “SCALE ON” and press **SELECT**.

Scale Mode– This allows you to customize your display for your application. By example: if your process is sending a 4-20mA signal to the SPA² and you wish to view the input as 0-100% then this can be accomplished with the Scale Mode feature.

9. “EXIT OPTNS” appears. Press **SELECT**. Proceed to the “SCALE INPUT” menu.

Figure 7. CONFIG OPTNS Menu

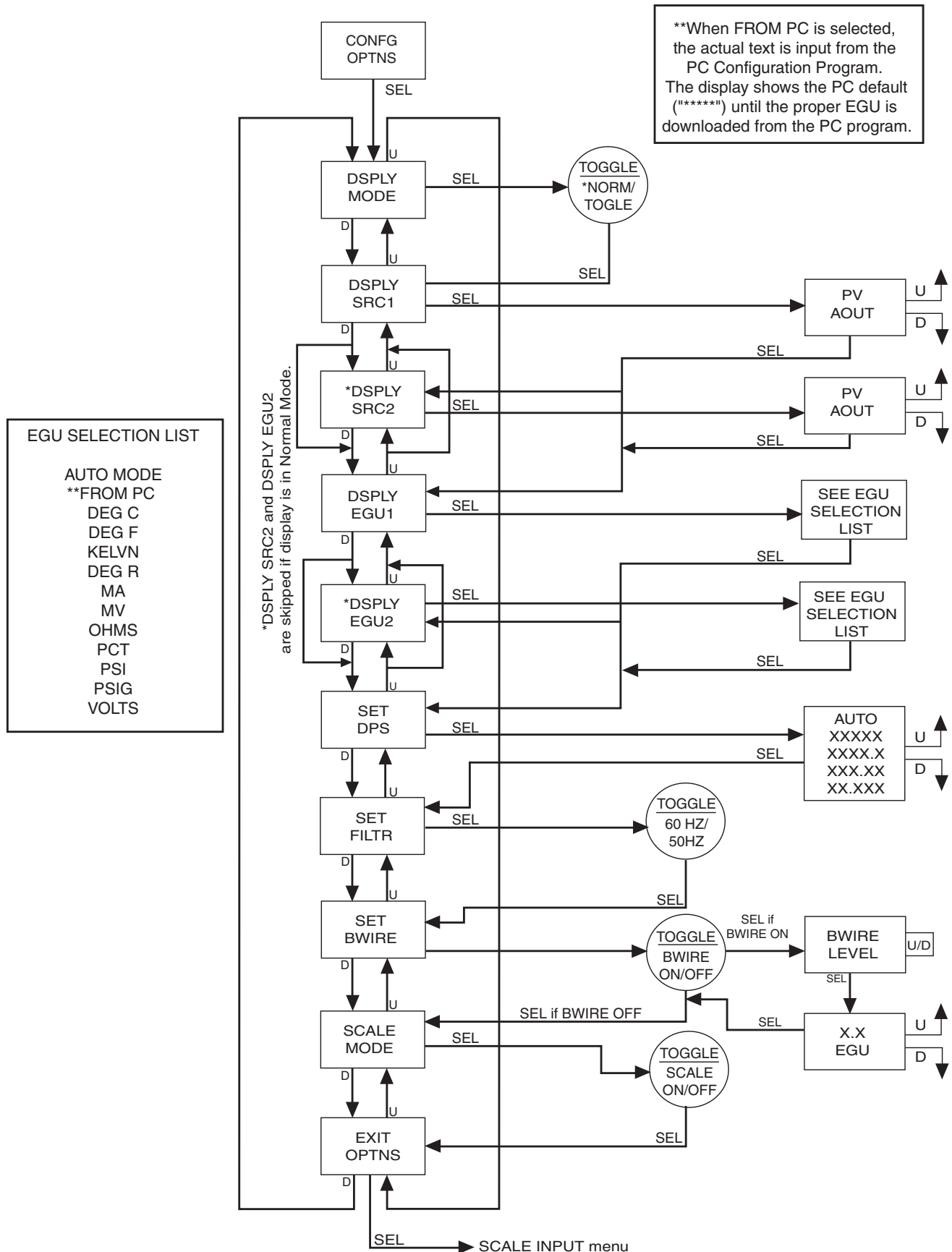

SPA²

Programmable Current/Voltage
Limit Alarm Trips

Scaling the Input

Figure 8 gives an overview of the Input Scaling menu.

Scaling allows you to take your PV (Process Variable) reading and manipulate it to a more customized display range. PV is the unit read after selecting your input type. For example, choosing a Current input would then produce a PV displayed in mA.

Also known as “Smart Ranging”, scaling of the SPA² (HLPRG) allows the user to set the zero and full scale values of the input from the intended application, without having to connect the unit to any calibration equipment.

Continue with the “SCALE INPUT” if you enabled scaling in the previous menu. To proceed, follow the steps below.

Note:

When using the front panel push buttons to enter your scaling values, you may enter only whole number increments. To adjust your value past the decimal point, you must use the PC Configuration Program.

1. At the “SCALE INPUT” display, press **SELECT**.
2. Press **SELECT** at the “INPUT ZERO” parameter and enter the value you want displayed when your input is at zero. Press **SELECT**.
3. Press **SELECT** at the “INPUT FULL” screen. Enter the value you wish displayed when your input is at full scale. Press **SELECT**.

If you selected “SCALE OFF” in the “CONFIG OPTNS” menu, the menu skips to Step 6. If you selected “SCALE ON”, proceed to Step 4.

4. Next, “SCALE ZERO” is displayed. Use the **UP** and **DOWN** buttons to adjust your scaled zero value. This is the value that will be displayed when you are at the zero end of your display range. Press **SELECT**.
5. “SCALE FULL” appears. Press **SELECT** to enter the menu. Enter the value you wish as your full scaled range—the value displayed when you are at the full end of your range. Press **SELECT**.
6. “EXIT SCALE” appears. If all scaling parameters have been set, press **SELECT**. The next menu selection to appear is “TRIM INPUT”.

Figure 8. SCALE INPUT Menu

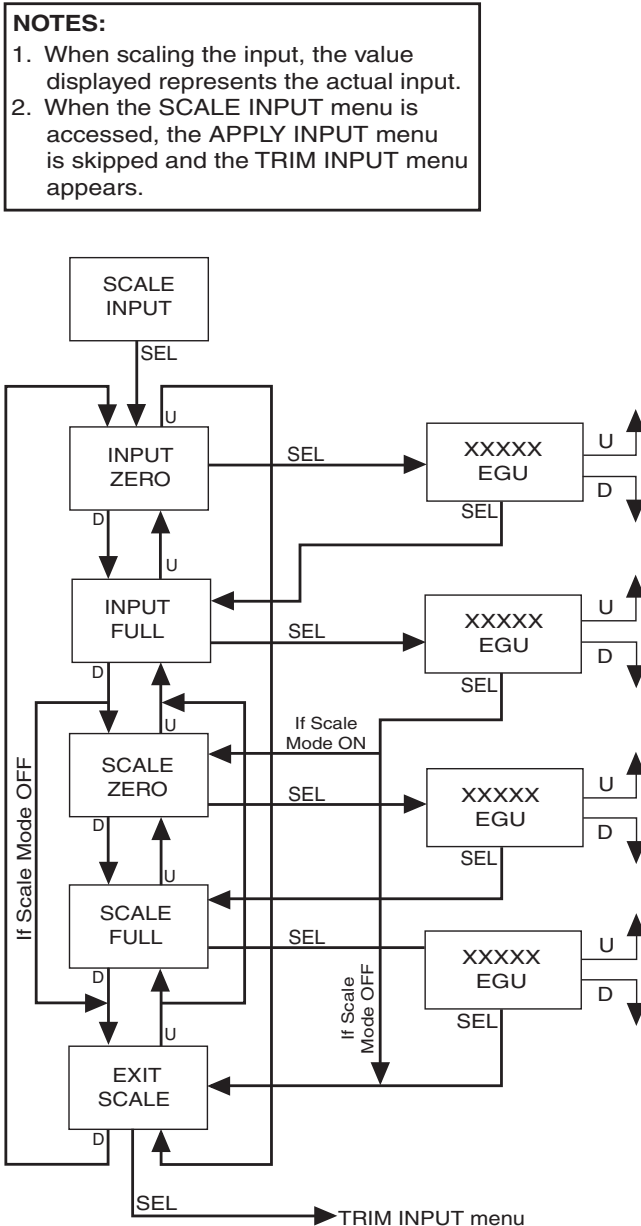

Applying Input (Bench Scaling)

Figure 9 gives an overview of the Apply Input menu.

With Bench Scaling, also called “Standard Ranging”, inputs are “captured” at their zero and full scale levels using external, calibrated equipment.

1. At the “APPLY INPUT” screen, press *SELECT*.
2. “APPLY ZERO” appears. Apply the input you wish as your zero and press *SELECT*. Wait until it is flashed on the display and press *SELECT* to capture.
3. Next, “APPLY FULL” is displayed. Apply the value of your full range and press *SELECT*. When this is flashed, press *SELECT* to capture.
4. Press *SELECT* at “EXIT APPLY” and exit the menu.

Figure 9. APPLY INPUT Menu

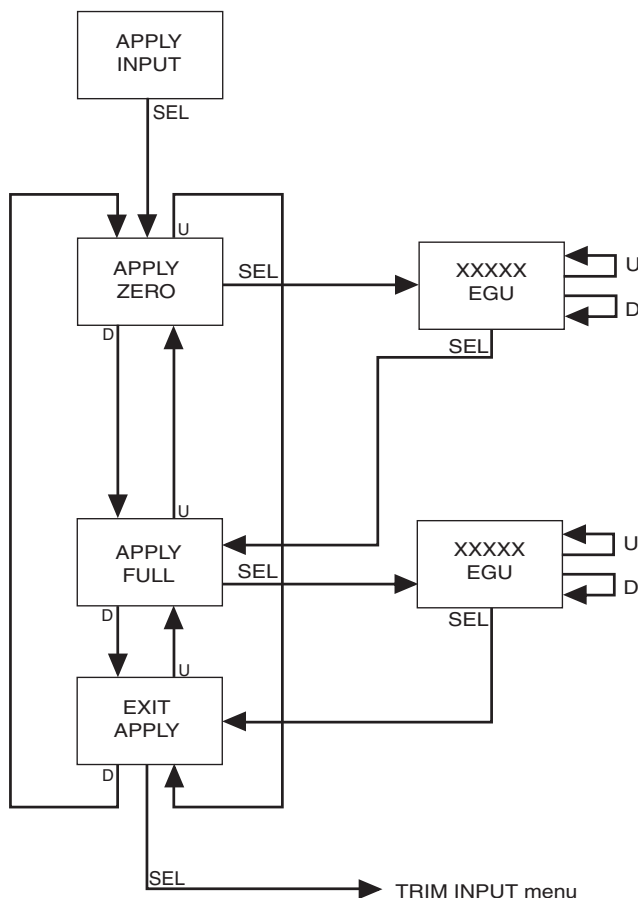

Input Trimming

Figure 10 gives an overview of the Input Trimming menu.

Input trimming increases the measurement accuracy of the parameter you are trimming by matching the reading of its actual input to its scaling. The SPA² offers the use of a factory-configured trimming feature (“FCTRY TRIM”) or user-set, one-point or two-point (“USER 1PNT” OR “USER 2PNT”) trimming.

Unit default is “FCTRY TRIM”. If another trimming selection had been made and you wish to return to the “FCTRY TRIM” feature, follow the instructions below.

1. Press *SELECT* at the “TRIM INPUT” SCREEN. Once the “TRIM MODE” appears, press *SELECT*.
2. “FCTRY TRIM” is displayed, press *SELECT*. This takes you to the “EXIT TRIM” screen.
3. To exit, press *SELECT*.

To input user-specific trim values, perform the following steps:

1. At the “TRIM INPUT” display, press *SELECT*. When “TRIM MODE” appears, press *SELECT* again. Use the *UP* and *DOWN* buttons to reach the user-set trimming menus. Press *SELECT* once the desired parameter is displayed—“USER 1PNT” or “USER 2PNT”.
2. “TRIM ZERO” appears. To program, press *SELECT*. Your present zero scaling value is shown and prompts you to “APPLY” your value. Press *SELECT*, once your value is present and flashing at the appropriate input terminals, press *SELECT* again. If you selected “USER 1PNT” trimming, “EXIT TRIM” appears. Press *SELECT* to reach the “CONFIG AOUT” menu (or “CONFIG ALARM” menu if the -AO option is not enabled). Proceed to Step 3 for “USER 2PNT” trimming.
3. If you selected “USER 2PNT” trimming, repeat the instructions in Step 2 for the “TRIM FULL” setting. Press *SELECT* when “EXIT TRIM” is displayed to reach the “CONFIG AOUT” menu (or “CONFIG ALARM” menu if the -AO option is not enabled).

Note:

Trim only the zero and full values entered in the “SCALE INPUT” menu through the front panel pushbuttons. To trim values other than those specified in the “SCALE INPUT” menu, you must use the PC Configuration Software program.

SPA²

Programmable Current/Voltage Limit Alarm Trips

Figure 10. TRIM INPUT Menu

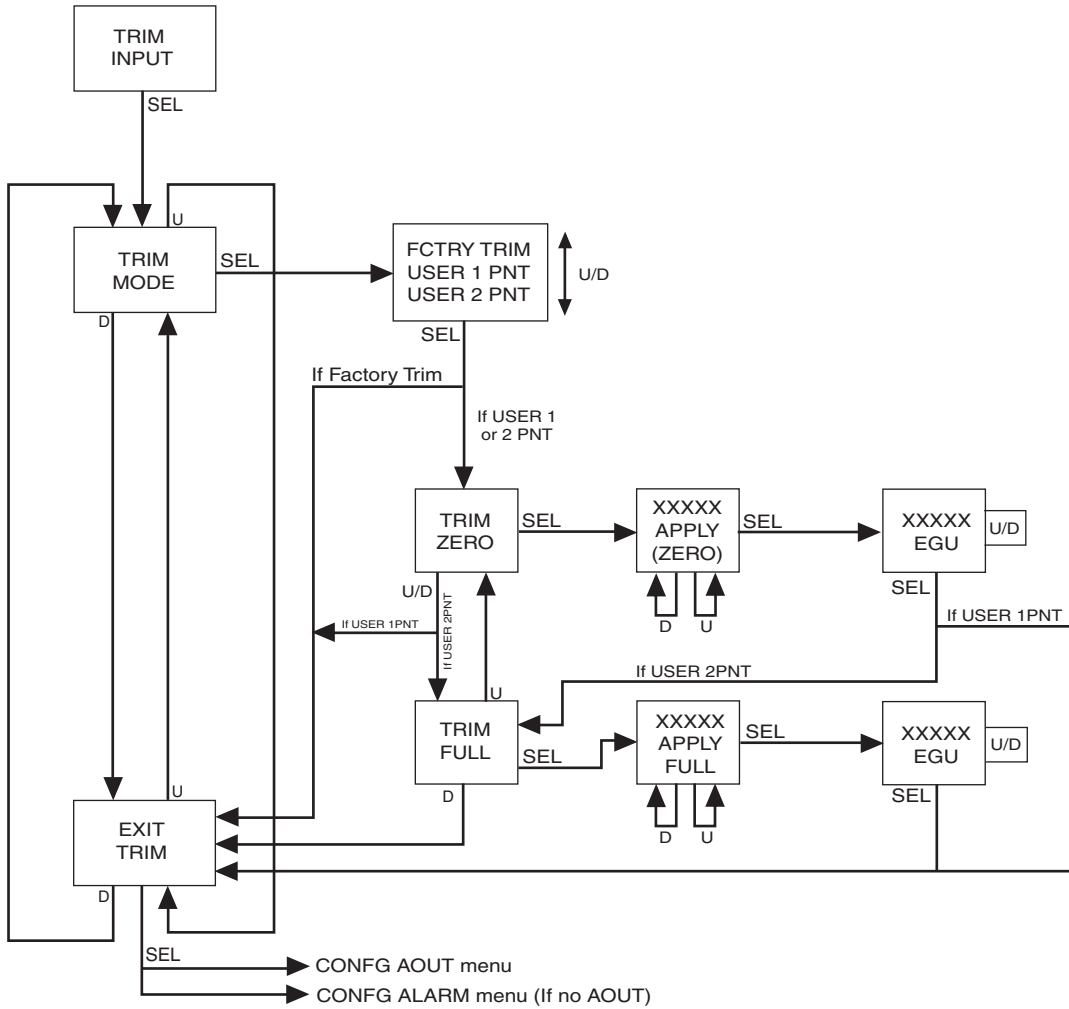

Configuring the Analog Output (-AO Option)

Figure 11 gives an overview of the Analog Output Configuration menu.

If your unit is equipped with the -AO option, use this menu for configuration.

1. Press *SELECT* at the “CONFIG AOUT” display. This sends you to the “SEL AOUT” section. Press *SELECT* and use the *UP* and *DOWN* buttons to toggle between current and voltage. When the selection you desire is displayed, press *SELECT*.
2. Once you reach the “SET DAMP” field, you may skip the damping parameter, by using the *Down* button to reach the next field. To set damping, proceed to Step 3.

3. To set damping, press *SELECT* at the “SET DAMP” display. Use the *UP* and *DOWN* buttons to enter a value between 0 and 30 seconds; press *SELECT*.
4. Press *SELECT* at “FAIL MODE” to program the setting. Choose “FAIL HIGH” or “FAIL LOW”. This sends you to “EXIT AOUT”.

HIGH/LOW– Choosing either of these options will send the output to a High (23.6mA for current; 11.0V for voltage) or Low (3.6mA for current; -0.5V for voltage), respectively.

Figure 11. CONFIG AOUT Menu

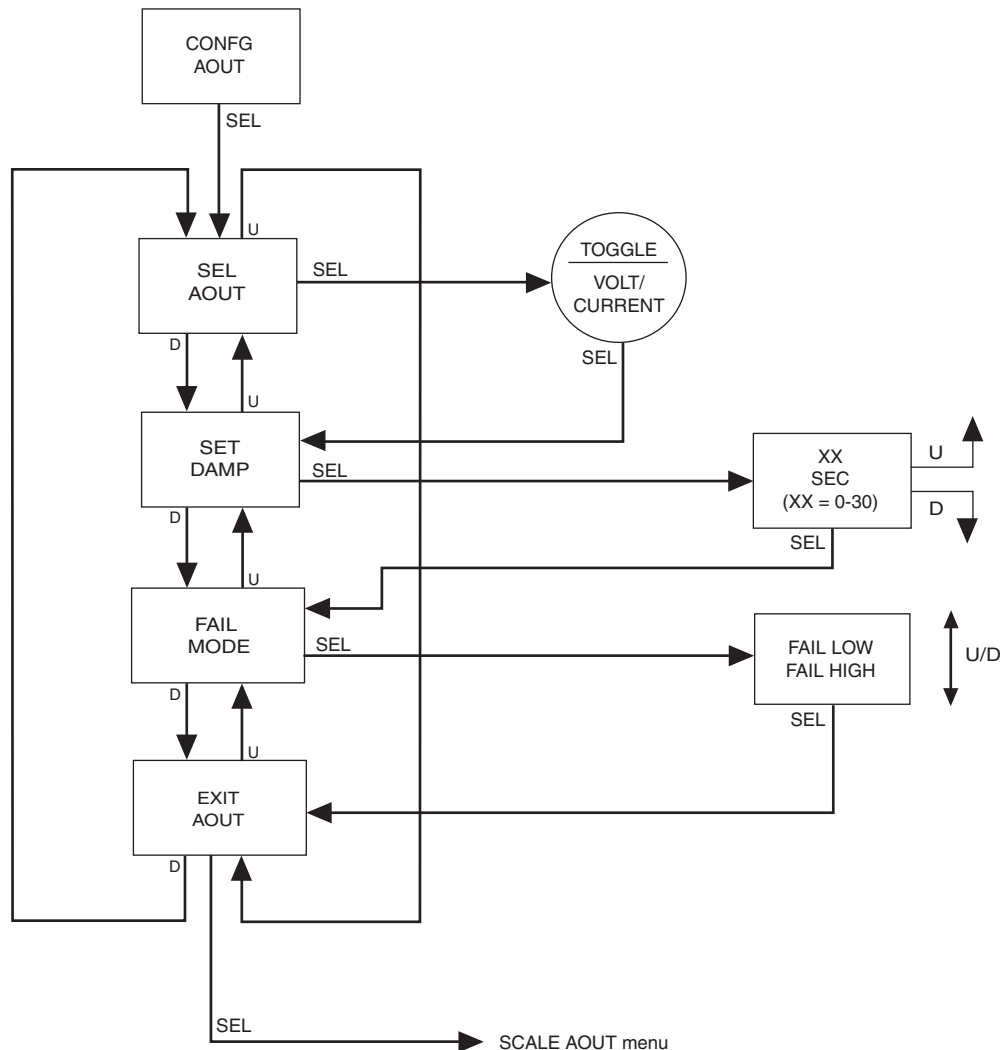

SPA²

Programmable Current/Voltage
Limit Alarm Trips

Scaling the Analog Output (-AO Option)

Figure 12 gives an overview of the Analog Output Scaling menu.

Follow these instructions to scale the analog output after you have performed the configuration.

Note:

When using the front panel pushbuttons to enter your scaling values, you may enter only values to one decimal place (tenths). To adjust your value past one decimal place, you must use the PC Configuration Program.

1. At the "SCALE AOUT" display, press *SELECT*.
2. Press *SELECT* at the "AOUT ZERO" parameter and enter the value you want to output when your input is at zero. Press *SELECT*.
3. Press *SELECT* at the "AOUT FULL" screen. Enter the value you want to output when your input is at full scale. Press *SELECT*.
4. "EXIT SCALE" appears. If all scaling parameters have been set, press *SELECT*.

Figure 12. SCALE AOUT Menu

NOTES:

1. When setting zero and full values, the values displayed are the analog output. Zero and full in mA or Volts (depending upon the output configuration).
2. Update your analog output during -AO scaling.
3. Rearranging values nulls your trim value.
4. Implement "auto increment" when incrementing and decrementing zero and full counts.

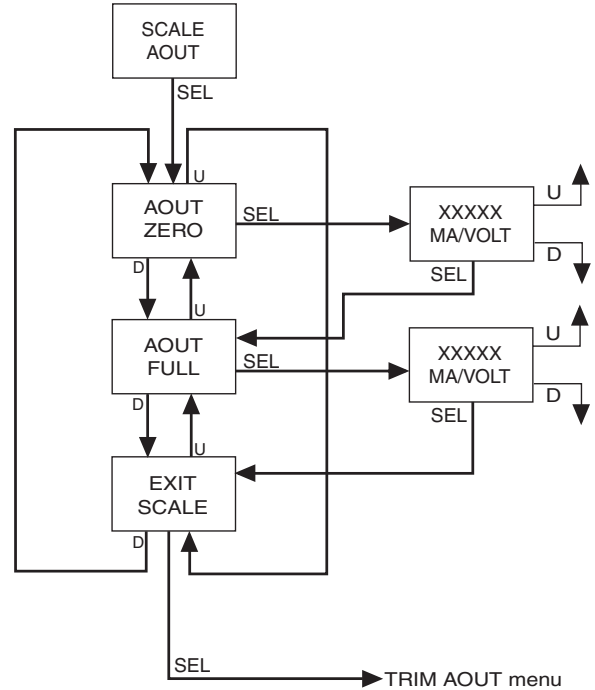

Trimming the Analog Output (-AO Option)

Figure 13 gives an overview of the Analog Output Trimming menu.

Output trimming increases the measurement accuracy of the SPA² by calibrating its analog output to the device that is receiving the output. This ensures that the instrument is being correctly interpreted.

Connect the unit as shown in Figure 14 and allow five minutes for warm up and stabilization.

1. At the “TRIM AOUT” display, press *SELECT*.
2. “TRIM ZERO” appears. Press *SELECT*. The value 0.000 (mA or V depending on the set up) is shown. While monitoring your reading on the meter, use the *UP* and *DOWN* buttons to adjust the output to the desired level. Use the meter in the set up to monitor the output as it is adjusted. When the output is set as desired, press *SELECT*.

Note:

The value on the LCD is the value that must be trimmed in order to adjust to the desired level.

3. Press *SELECT* at “TRIM FULL” and repeat Step 2. Press *SELECT*. “FCTRY TRIM” is shown on the display.
4. If you wish to **disable** the user-configured trimming values and use factory trimming, press *SELECT* at the “FCTRY TRIM” screen. Use the *UP* and *DOWN* buttons to choose “YES”; press *SELECT*. “TEST AOUT” is brought up on the display.

By selecting “NO” at the “FCTRY TRIM” screen, the user-configured trim values will be used.
5. In order to check output performance and accuracy, you may want to perform an output test. If you choose to enable this test, follow the instructions in Step 6. To bypass this feature, use the *DOWN* button and scroll to “EXIT TRIM”.
6. To enable the analog output test, press *SELECT* at the “TEST AOUT” display. Use the *UP* and *DOWN* buttons to set your output test value (this figure must fall within your sensor configuration range value) and press *SELECT*. “EXIT TRIM” appears; press *SELECT*.

Figure 13. TRIM AOUT Menu

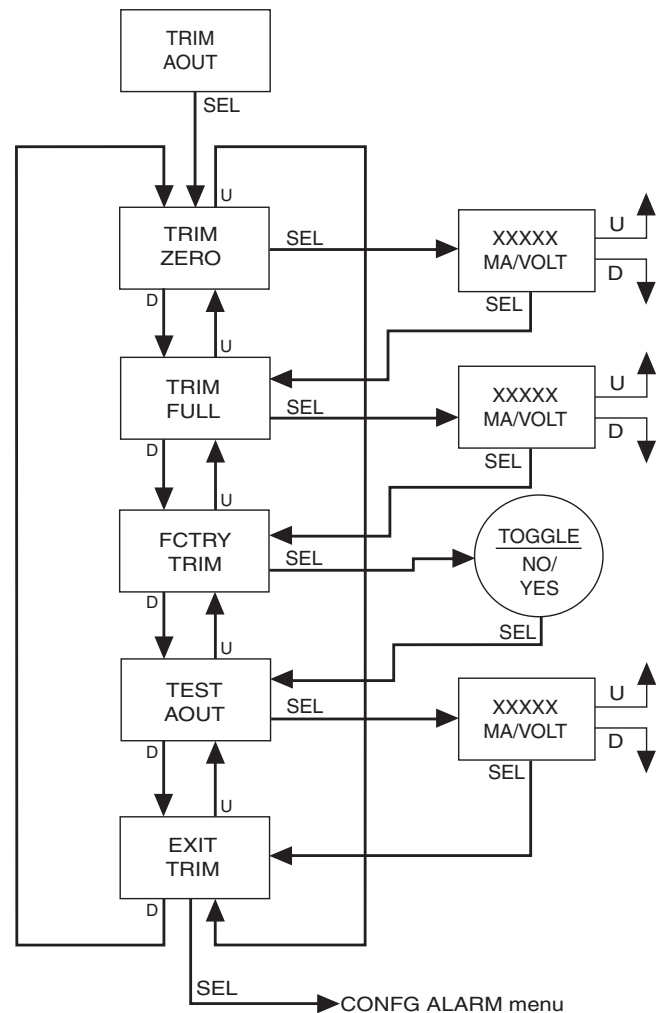

SPA²

Programmable Current/Voltage Limit Alarm Trips

Figure 14. SPA² (HLPRG) Trimming Hook-Up Diagram For Front Panel Configuration

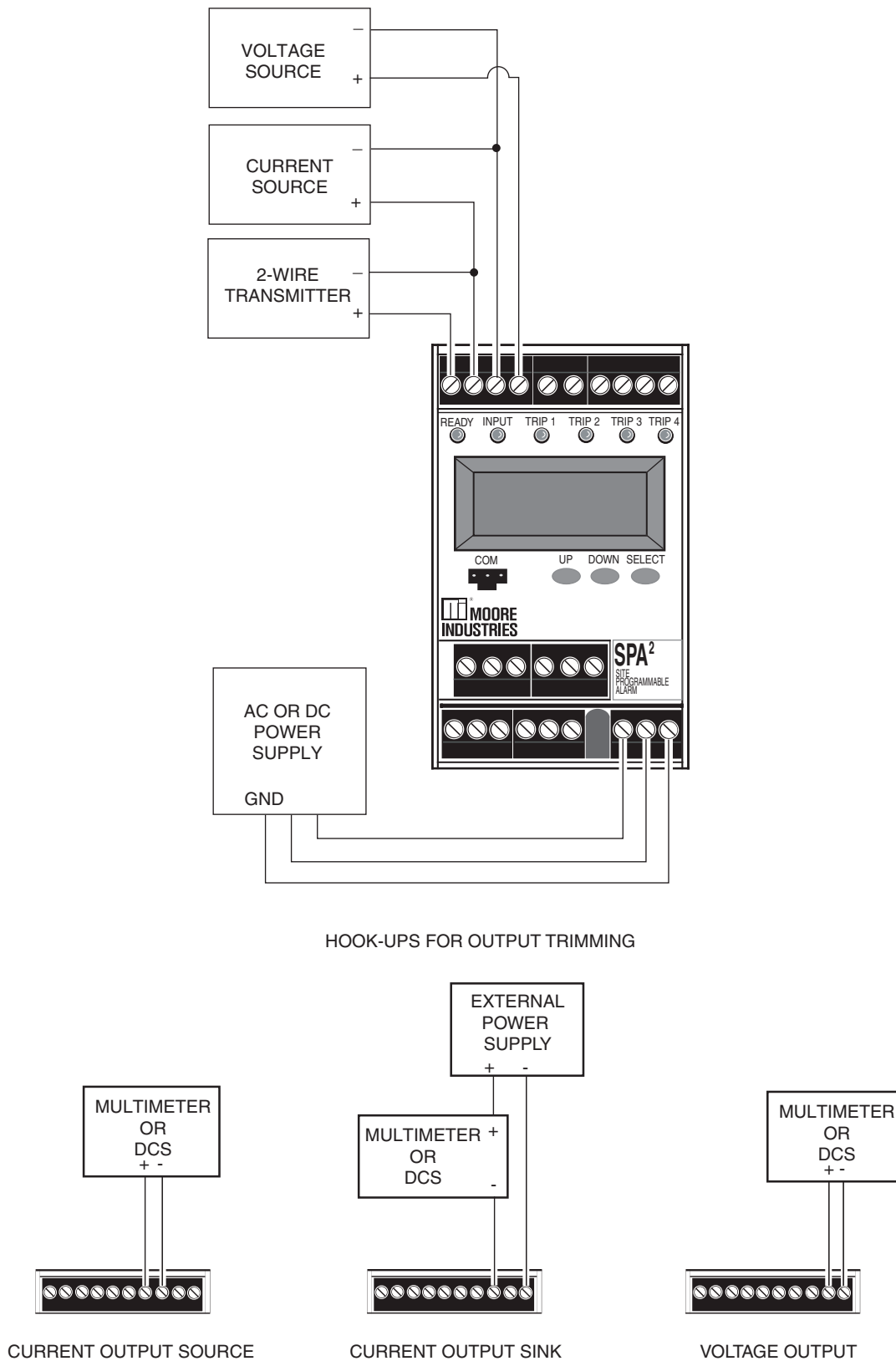

Configuring the Alarm(s)

The SPA² offers you four alarms. Each of these alarms may be configured as trip, fault or rate of change alarms. The instructions below will explain the steps to follow in order to set each type of alarm. This section will be divided into three sub-sections: “Trip Alarm Configuration”, “Fault Alarm Configuration” and “Rate of Change Alarm Configuration”. Depending upon the type of alarm you are setting, you may refer to the section specific to your need at the time.

Trip Alarm Configuration

Figure 15 gives an overview of the Trip Alarm Configuration menu.

Trip alarms are used if the user desires an alarm condition if a process value deviates from a set trip point.

1. At the “CONFIG ALARM” menu, press *SELECT*. Use the *UP* and *DOWN* buttons to toggle between the four alarms. When the desired alarm appears, press *SELECT*.
2. At the “ALARM TYPE” menu press *SELECT*. From here you will choose your alarm type. Use the *UP* and *DOWN* buttons to scroll through the selections. Press *SELECT* once “ALARM TRIP” is displayed.
3. At “ENTER TRIP”, press *SELECT* and enter your alarm trip value. Use the *UP* and *DOWN* buttons to select your trip value; press *SELECT*.
4. Press *SELECT* at “ENTER DBAND” and enter your dead band value if using dead band. Press *SELECT* once your desired setting appears.

Dead Band– The Dead Band is the range within which an alarm relay remains in an alarm condition even after the monitored process variable input has returned to a safe level, at or below/above the trip point setting.

5. Press *SELECT* at “ENTER DELAY” and input your desired delay time by using the *UP* and *DOWN* buttons.
Delay– When your unit is in an alarm condition, the delay is the amount of time you set (0-120sec) to elapse before a relay trip.
6. Pressing *SELECT* at the “SET HI/LO” menu directs you to configure the alarm as an “ALARM HI” or “ALARM LO”. Use the *UP* and *DOWN* buttons to reach your selection and press *SELECT*.

ALARM LO– You are notified if your process input drops below your trip point setting.

ALARM HI– You are notified if your process input exceeds your trip point setting.

7. At the “SET LATCH” display, press *SELECT* and choose “LATCH ON” or “LATCH OFF” using the *UP* and *DOWN* buttons; press *SELECT*.

Latching Alarm– When a SPA² is configured with latching alarms, an alarm condition will not “clear” (the relay will not change state) until the input returns to a non-alarm state **AND** manual reset terminals are shorted and then opened.

These manual reset terminals, labeled “MR” are located on the top row of the SPA².

8. Press *SELECT* at “SET FSAFE” to enter the menu. Then use the *UP* and *DOWN* buttons to switch from “ALARM FSAFE” to “ALARM NONFS”. Make your selection and press *SELECT*.

Fail Safe (ALARM FSAFE)– Will remain in an alarm condition even if power to the unit is removed. Its alarm trip relays are energized whenever the process input is in a non-alarm condition (including any dead band setting). These relays de-energize when the process input trips the alarm.

Non Fail Safe (ALARM NONFS)– With this type of alarm relays are energized whenever the process input is in an alarm condition. These relays de-energize when the process input returns to the reset point (including any dead band).

SPA²

Programmable Current/Voltage Limit Alarm Trips

Figure 15. CONFIG ALARM MENU (Trip Alarm)

- NOTES:**
1. Smart Ranging skips standard ranging and goes to dead band.
 2. Input flashing during standard ranging.

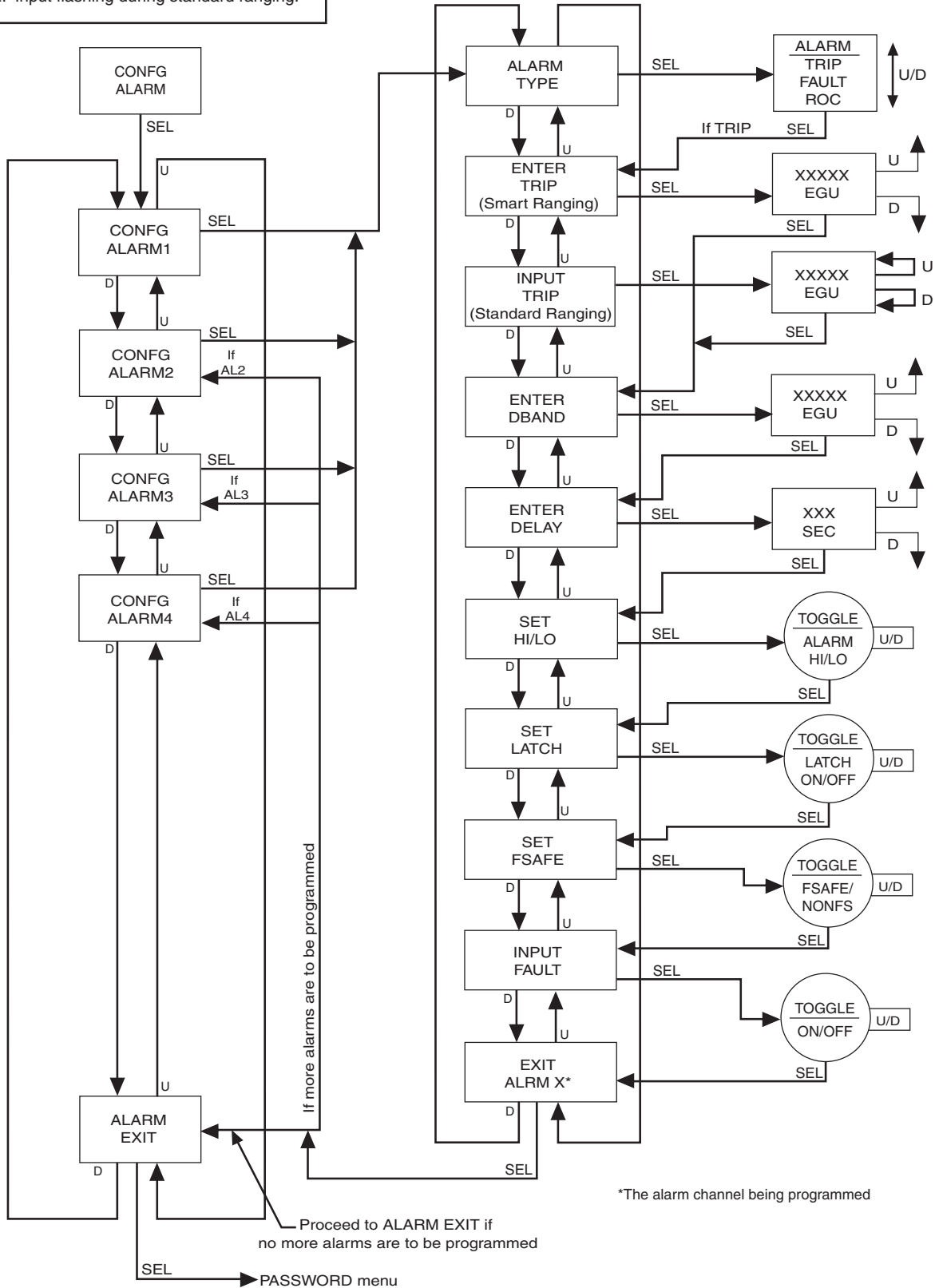

9. "INPUT FAULT" appears. Select whether or not to enable the input failure alarm by using the *UP* and *DOWN* buttons; press *SELECT*. "EXIT ALARM X"* appears. Press *SELECT*.

Input Fault Alarm (INPUT FAULT)– If enabled, this alarm will notify the user upon a breakdown of input .

10. If you are to program other alarms, use the *UP* and *DOWN* buttons to reach your next alarm and follow the steps described in the appropriate alarm configuration section.

If you have completed your alarm configurations, use the *UP* and *DOWN* buttons to bypass the alarm menu. To exit, press *SELECT* at the "ALARM EXIT" display.

Fault Alarm Configuration

Figure 16 gives an overview of the Fault Alarm Configuration menu.

Fault alarms are set in order to notify you of any fault conditions during your process. If you wish an alarm condition when a malfunction occurs, use the Fault Alarm

1. At the "CONFIG ALARM" menu, press *SELECT*. Use the *UP* and *DOWN* buttons to toggle between the four alarms. When the desired alarm appears, press *SELECT*.
2. At the "ALARM TYPE" menu press *SELECT*. From here you will choose your alarm type. Use the *UP* and *DOWN* buttons to scroll through the selections. Press *SELECT* once "ALARM FAULT" is displayed.

Below are the configuration options you are given in setting up the fault alarm. You may choose any combination of alarms including all three.

INPUT FAULT– You are notified upon breakdown of your input.

INPUT SAT– Should the input become overloaded or saturated, your alarm would activate.

SPA FAULT– Choosing this parameter activates the alarm at any failure that occurs in the SPA² itself.

Note:

Enabling all fault alarm configurations will activate the alarm at any failure that occurs (refer to Table 4 in the Error Codes section of this manual).

3. "INPUT FAULT" appears. Press *SELECT* at "INPUT FAULT". Dependent upon whether you wish the alarm activated due to an input fault, use the *UP* and *DOWN* buttons to scroll through the "ALARM ON" and "ALARM OFF" options. Once you have made a selection, press *SELECT*.
4. Press *SELECT* at the "INPUT SAT" display. You are given the choice of "ALARM ON" or "ALARM OFF" by using the *UP* and *DOWN* buttons. Choose your setting and press *SELECT*.
5. Next, the "SPA FAULT" menu is displayed. Press *SELECT*. Toggle between "ALARM ON" and "ALARM OFF" by using the *UP* and *DOWN* buttons and press *SELECT* when the setting you desire is displayed.
6. Press *SELECT* at "ENTER DELAY" and enter your desired delay time by using the *UP* and *DOWN* buttons.
7. At the "SET LATCH" display, press *SELECT* and choose "LATCH ON" or "LATCH OFF" using the *UP* and *DOWN* buttons; press *SELECT*.

Refer to the "Trip Alarm Configuration" section for a description of delay and latching alarms.

8. Press *SELECT* at "SET FSAFE" to enter the menu. Then use the *UP* and *DOWN* buttons to switch from "ALARM FSAFE" to "ALARM NONFS". Make your selection and press *SELECT*. The "EXIT ALARM X"* appears. Press *SELECT*.

Refer to the "Trip Alarm Configuration" section for a description of fail safe and non fail safe alarms.

9. If you are to program other alarms use the *UP* and *DOWN* buttons to reach your next alarm and follow the steps described in the appropriate alarm configuration section.

If you have completed your alarm configurations, use the *UP* and *DOWN* buttons to bypass the alarm menu. To exit, press *SELECT* at the "ALARM EXIT" display.

*ALARM X denotes the alarm (1, 2, 3 or 4) that you are currently configuring.

SPA²

Programmable Current/Voltage Limit Alarm Trips

Figure 16. CONFIG ALARM Menu (Fault Alarm)

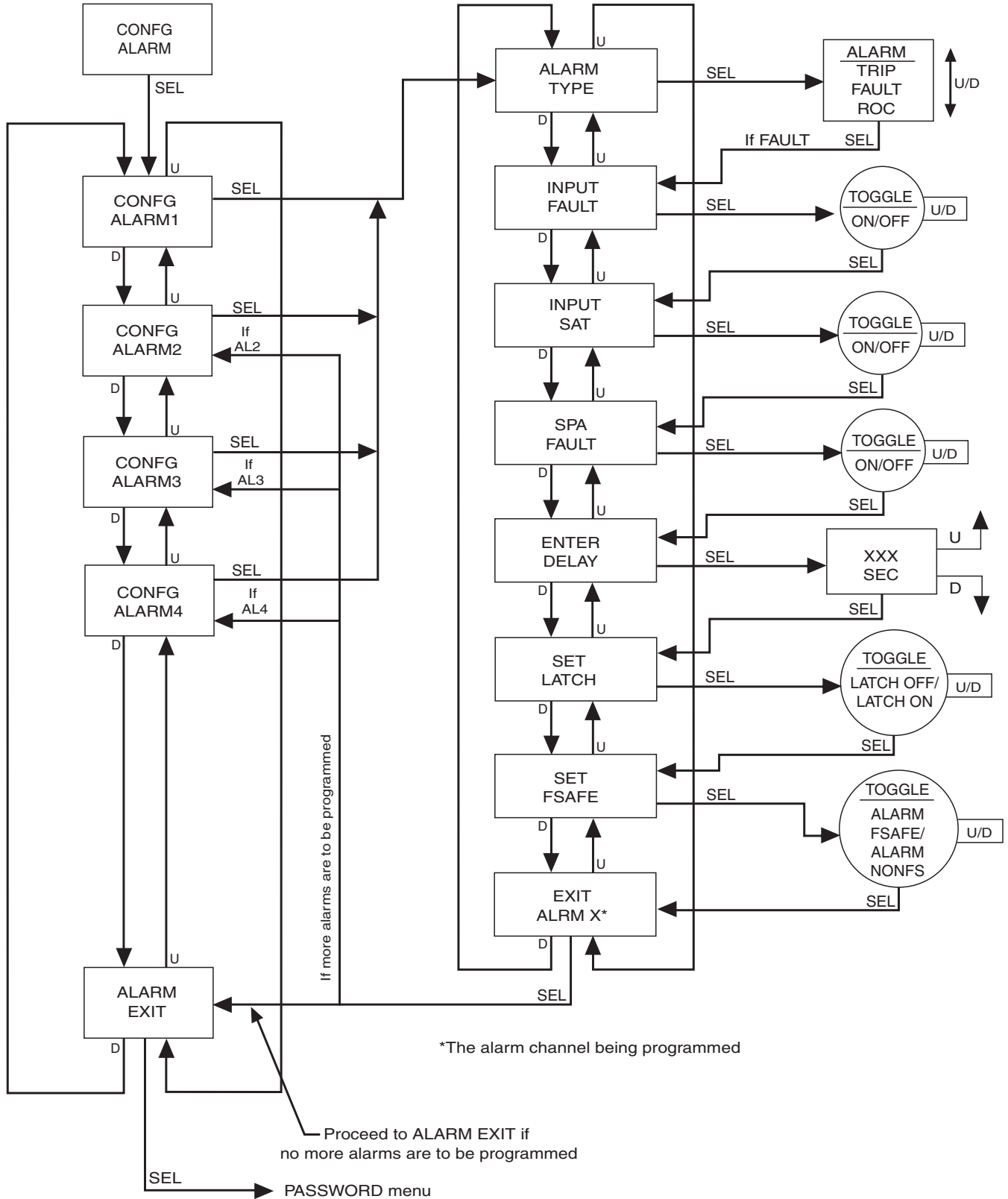

Rate of Change Alarm Configuration

Figure 17 gives an overview of the Rate of Change Alarm configuration menu.

If you wish to be notified when deviations outside of ranges you have set occur, use the Rate of Change Alarm. The alarm will be set according to the rate of change of the process variable over a set time period.

1. At the "CONFIG ALARM" menu, press *SELECT*. Use the *UP* and *DOWN* buttons to toggle between the four alarms. When the desired alarm appears, press *SELECT*.
2. At the "ALARM TYPE" menu, press *SELECT*. From here you will choose your alarm type. Use the *UP* and *DOWN* buttons to scroll through the selections. Press *SELECT* once "ALARM ROC" is displayed.

3. At "ENTER DELTA" press *SELECT* and use the *UP* and *DOWN* buttons to set your delta value. Press *SELECT*.

DELTA– This is the amount by which the process variable must change. You may enter a value less than one through the PC Configuration Program only.

4. At the "ENTER TIME" menu, press *SELECT*. Using the *UP* and *DOWN* buttons, set the time and press *SELECT*.

TIME– The span (1-60sec) in which the delta must change before the alarm is set.

Note:

When configuring a Rate of Change alarm, "LATCH ON" must be selected in the "SET LATCH" menu.

5. At the "SET LATCH" display, press *SELECT* and choose "LATCH ON" using the *UP* and *DOWN* buttons; press *SELECT*.

Refer to the "Trip Alarm Configuration" section for a description of latching alarms.

6. Press *SELECT* at "SET FSAFE" to enter the menu. Then use the *UP* and *DOWN* buttons to switch from "ALARM FSAFE" to "ALARM NONFS". Make your selection and press *SELECT*.

Refer to the "Trip Alarm Configuration" section for a description of fail safe and non fail safe alarms.

7. "INPUT FAULT" appears. Select whether or not to enable the input failure alarm by using the *UP* and *DOWN* buttons; press *SELECT*. "EXIT ALARM X"* appears. Press *SELECT*.

INPUT FAULT Alarm– If enabled, this alarm will notify the user upon a breakdown of input.

8. If you are to program other alarms, use the *UP* and *DOWN* buttons to reach your next alarm and follow the steps described in the appropriate alarm configuration section.

If you have completed your alarm configurations, use the *UP* and *DOWN* buttons to bypass the alarm menu. To exit, press *SELECT* at the "ALARM EXIT" display.

*ALARM X denotes the alarm (1, 2, 3 or 4) that you are currently configuring.

SPA²

Programmable Current/Voltage Limit Alarm Trips

Figure 17. CONFIG ALARM Menu (Rate of Change Alarm)

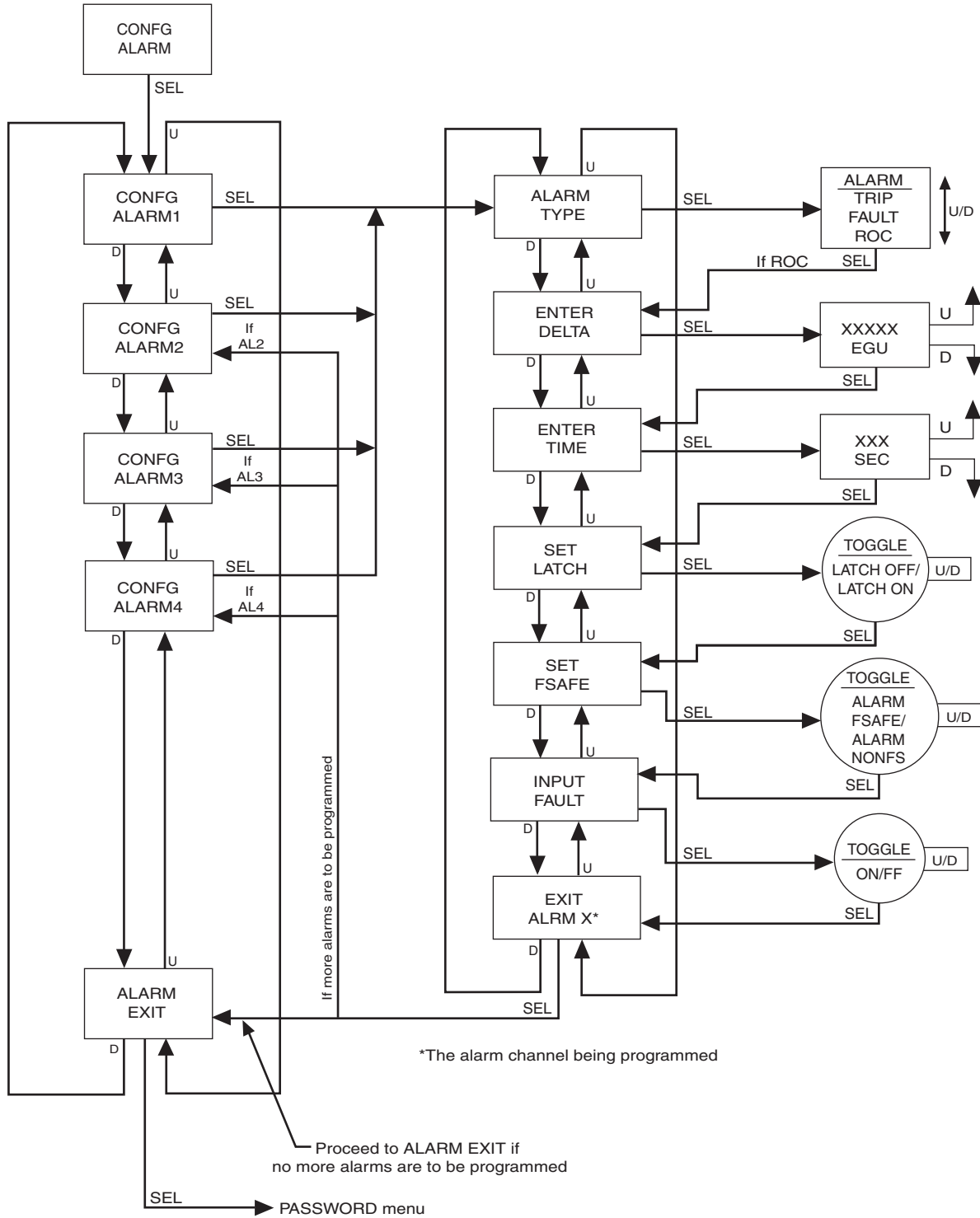

Password Configuration

Figure 18 gives an overview of the Password Configuration menu.

The password menu is accessible only when the security jumper is not installed (Figure 2) or when the password is entered correctly.

The last of your menus, “CONFIG PASWD”, is for password configuration.

1. At “CONFIG PASWD”, press *SELECT*. This puts you in the “PASS” menu. The previously saved password appears.
2. Use the *UP* and *DOWN* buttons to set a new password to any number between 0 and 9999. Press *SELECT*.
3. The “CONFIG EXIT” option appears. Press *SELECT* to return to the process variable display.

Figure 18. CONFIG PASWD Menu

NOTES:

1. The Password menu is accessible only when the security jumper is not installed or when the password is entered correctly.

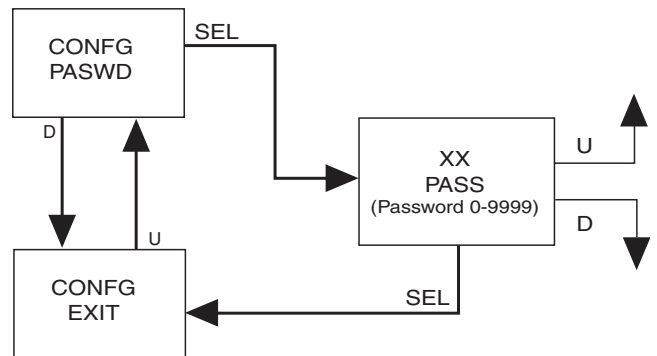

SPA²

Programmable Current/Voltage
Limit Alarm Trips

SPA² Configuration: PC Configuration Software

One of the benefits of the SPA² is that you may either use the external push button controls to set up the instrument, or use a PC and Moore Industries' Intelligent PC Configuration software.

In using the software program, settings are downloaded to the instrument in the form of a Configuration File and stored in the instrument's memory. You can save a backup copy of the file on your PC hard drive or disk. The SPA² communicates with the PC through an RS-232 connection to the PC's serial port.

Installing the Configuration Software

Refer to Table 3 for the equipment needed.

1. Insert the *Moore Industries Interface Solution PC Configuration Software* CD into the CD drive of the PC. Access the CD and open the "SPA² PC Configuration Software" folder.
2. Double-click the installation program located in the folder. Follow the prompts to correctly install the program.

Once the Configuration Program is installed onto your PC, the SPA² can be connected to equipment to simulate input and monitor output. You can then change the operating parameters of the alarm.

No Alarm Needed

It is not necessary to connect the SPA² to a PC to create configuration files using the software. The Configuration Program can be run without connecting an alarm, and **most** parameters can be set without benefit of input from a sensor or SPA².

This makes it easy to create a set of operating parameters, save them to disk, and download them to one or more instruments at a later time.

The SPA² **must** be connected to the PC in order to: trim input, trim output, assign a tag, perform a loop test, receive (via download) a configuration file, and save the configuration file (via upload) from the SPA²'s memory.

Connecting the SPA² to the PC

Connect the RS-232 end of the cable to the PC's COM port.

See Table 3 for information on the necessary equipment.

Table 3. Necessary Equipment to Configure the SPA² (HLPRG)

Device	Specifications
Current or Voltage Source (optional)	Accurate to 0.05% of span for the intended application
Power Supply	24Vdc, ±10% or 117/230Vac, 110Vdc (depending on model)
Multimeter (optional)	Accurate to ±0.009% of span; e.g., HP Model 3478A
Personal Computer	80386-based (or faster) IBM PC, or 100% compatible; 4Mb free RAM; 8Mb recommended; 20Mb free disk space on hard drive (More RAM & hard disk space is required for Windows 98, NT 2000 or XP) Microsoft Windows® 95, 98, NT, 2000 or XP Internet Explorer 3.0+ (required for HelpMap) 1 (one) serial port (COM 1, 2, 3, or 4) set to 19.2kbaud, no parity, 8 data bits, and 1 stop bit
Moore Industries PC Configuration Software	Version 1.0 or greater, successfully installed to the hard drive
Communication Cable	Part# 803-053-26A

SPA²

Programmable Current/Voltage
Limit Alarm Trips

Figure 19. SPA² (HLPRG) Hook-Up Diagram For PC Configuration

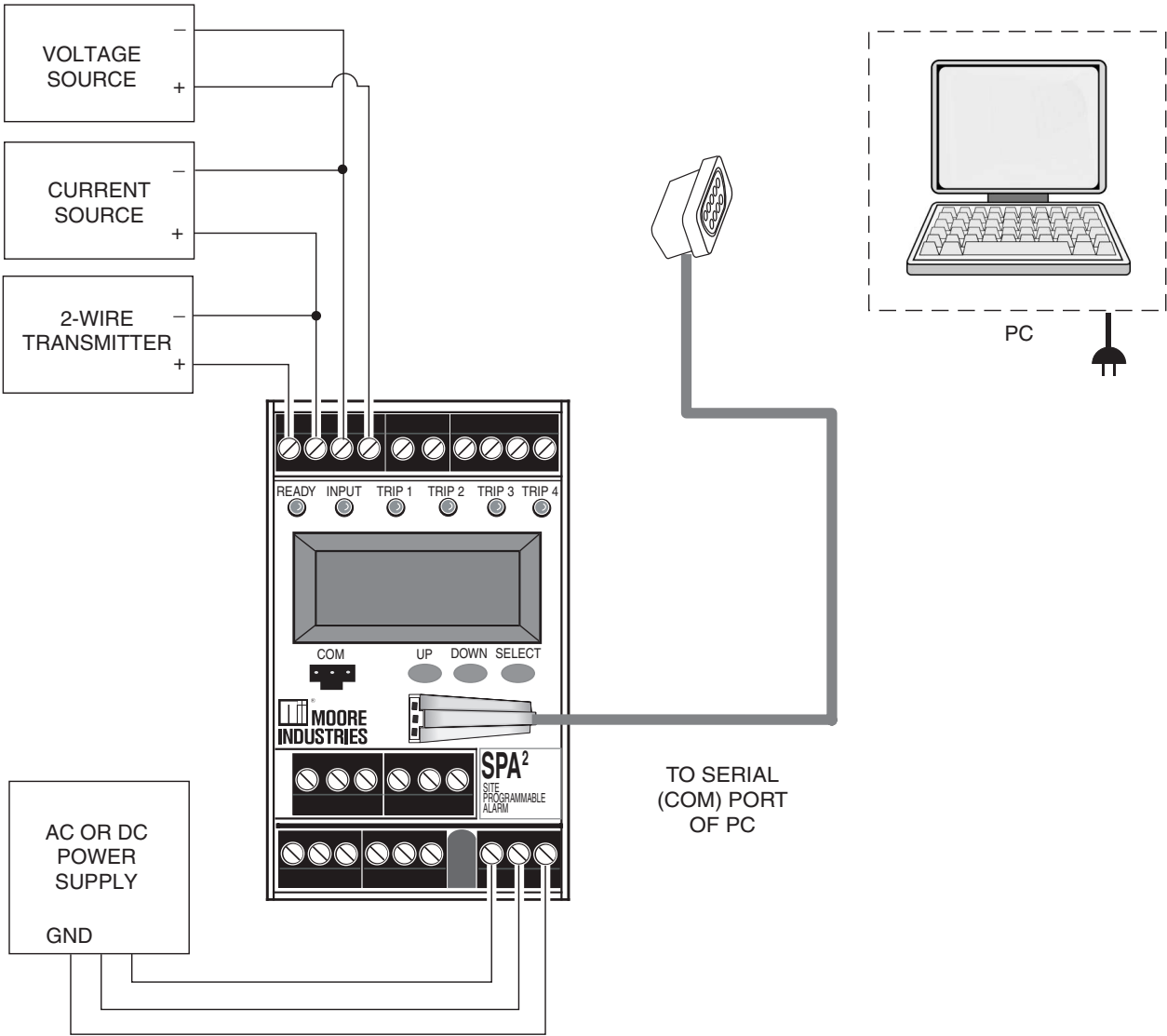

SPA²

Programmable Current/Voltage
Limit Alarm Trips

PC Configuration Software Summary

Figure 20. SPA² (HLPRG) Main PC Screen

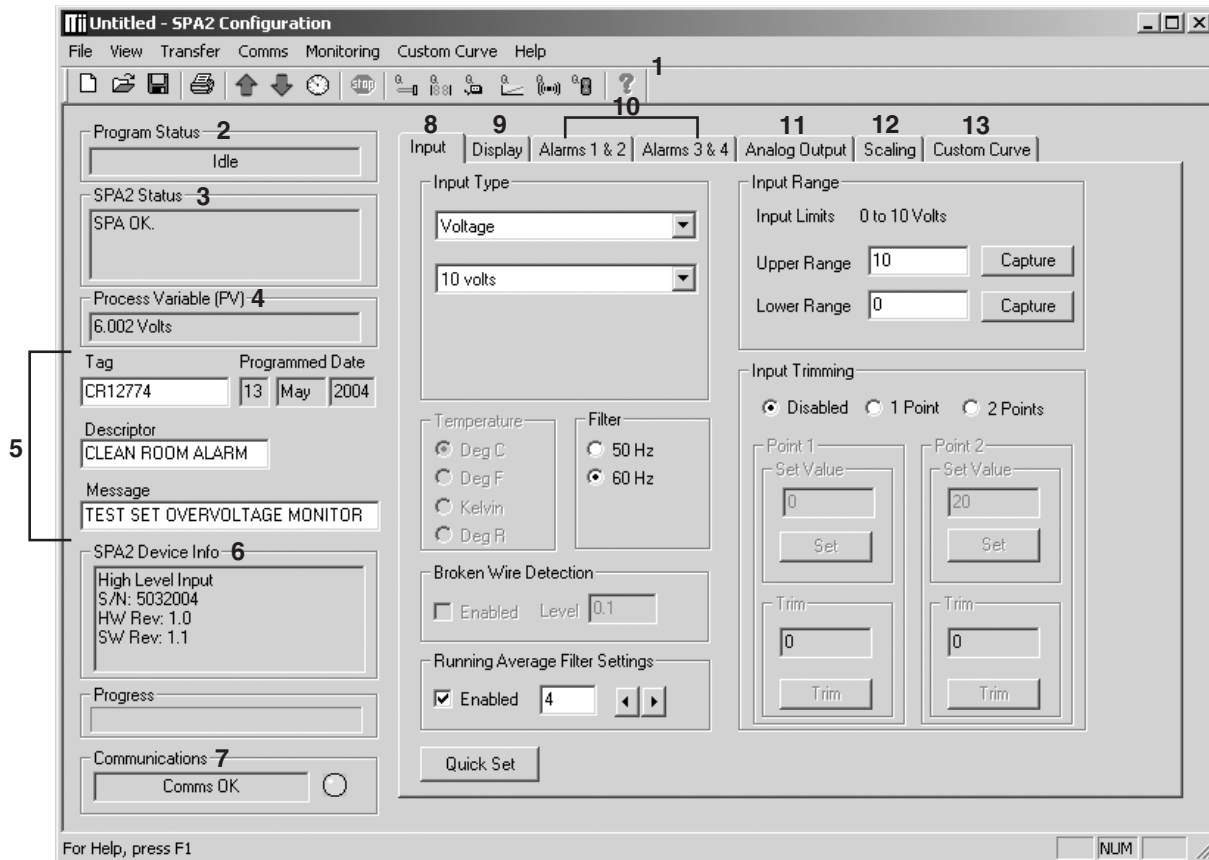

Once the default configuration has been saved to disk, it is safe to program other parameters. The PC Software is made up of these sections:

1. Tool Bar/Status Bar– Dropdown menus and corresponding icons allow you to perform various functions throughout the PC Configuration Program. Refer to the *Status and Tool Bar Legend* for a complete description.

2. Program Status– This portion of the program displays the activity of the connected unit. It will display such messages as: Reading SPA Info, Idle, Monitoring Variables and Monitor Fail.

3. SPA² Status– Indicates if there are problems or faults with the instrument.

4. Process Variable (PV)– Displays the selected Process Variable.

5. Identification Parameters– Use this parameter to place an identifying “Tag” (12 alphanumeric characters max.), “Descriptor” (16 alphanumeric characters max.) or “Message” (32 alphanumeric characters max.).

You may also use the *Quick Set* feature to set these features and download them. Simply click the  button in the Tool Bar.

6. SPA² Device Info– This “read-only” display indicates instrument configuration, device identification, hardware revision and software revision.

7. Communications– Notifies user of current PC connection/communications status.

8. Input Tab– Use this tab to set your input parameters. Refer to the *Input* section for a complete description.

9. Display Tab– Used to set up the appearance of the SPA²'s LCD screen. Refer to the *Display* section for a complete description.

10. Alarms Tab (1 & 2 and 3 & 4)– Alarm parameters are configured using these windows. Alarms 1 & 2 are located in the same window. Alarms 3 & 4 are grouped together in another window. Refer to the *Alarms* section for a complete description.

11. Analog Output Tab– Configuration of the analog output (if your instrument is equipped with the -AO option) is performed here. Refer to the *Analog Output* section for a complete description.

12. Scaling Tab– If you choose to enable the scaling feature, the parameter would be configured at this window. Refer to the *Scaling* section for a complete description.

13. Custom Curve Tab– The SPA² has two modes of operation: linear mode and custom mode. In linear mode, the scaled output is proportional to the scaled input. In custom mode, reached by selecting the *Custom Curve* tab, you define a special linearization function. Refer to the *Custom Curve* section for a complete description.

Note:

You may not use the front panel push buttons for Custom Curve configuration. The Custom Curve parameter can ONLY be configured using your PC and PC Configuration Software Program.

Status and Tool Bar Legend

	Allows such functions as New, Open, Save and Print
	Controls whether Tool and Status Bars are viewed on the screen
	Allows you to Upload and Download configurations
	Select the PC Port (Com Port) that you will use
	Allows you to Monitor and Stop monitoring processes
	Provides functions specific to your Custom Curve table
	Displays the version of the SPA ² Configuration Program
	Quick Set Buttons

Configuration Screens

Note:

Unless otherwise noted, ensure that the PC Program is idle before making any selections or configuration changes to the parameters and windows of the program. Also, when attempting to download, upload or Quick Set, monitoring must be stopped. To do this, click “Stop” in the Monitoring dropdown menu, or click the “Stop Monitoring” icon.

Input

Figure 21. Input Tab

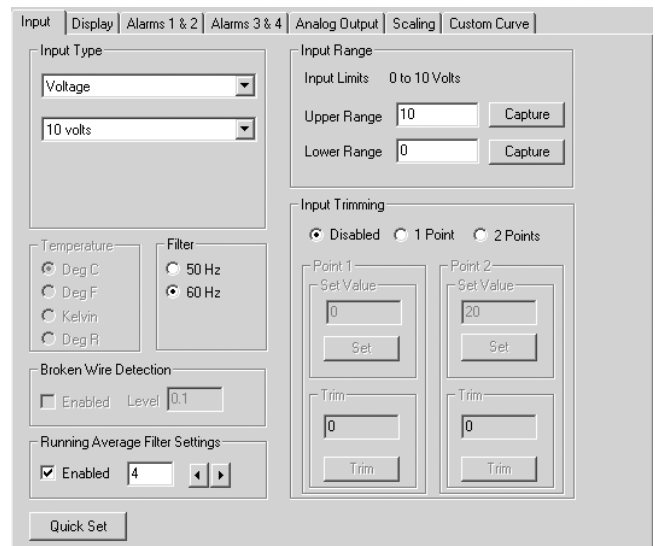

Input Type– Select your input configuration (Current or Voltage) and the respective range of your input.

Filter– This setting is used to configure the input filter. This filter is designed to reduce the effects of mains-induced noise. The input filter frequency value should be set to the frequency of the local AC supply– either 50Hz or 60Hz.

Broken Wire Detection– Refer to the **“Caution”** on Page 14 regarding Broken Wire Detection. The SPA² monitors your process variable. If the monitored value falls equal to or below a set value, then a state of Broken Wire is declared.

1. Check the “Enabled” box in order to activate Broken Wire Detection.
2. In the “Level” textbox, enter the set value you choose as your limit. The value that you enter must be greater than zero and less than your “Lower Range” value (see *Input Range*).

SPA²

Programmable Current/Voltage Limit Alarm Trips

Running Average Filter Settings– This function is for filtering the input signal. The SPA² provides this filter with a user-selected range between 1 and 16. Factory default is 4.

Note:

A higher Running Average Filter setting provides smoother output transitions; however, reduces response time. Conversely, a lower setting provides a faster response time, but may seem more unstable.

Input Range– Allows you to set your upper and lower range values within the range chosen in the *Input Type* section.

The desired Upper and Lower Range settings can be entered via your PC keyboard or captured. To capture an input, follow the steps below.

1. Apply the desired Upper Range input and press the corresponding “Capture” button.
2. Repeat Step 1 to configure the Lower Range value.

Input Trimming– Input Trimming increases the measurement accuracy of your instrument by matching the reading of its actual input to either a calibrated source or the device to which it is connected. This verifies that the input to the transmitter is being interpreted correctly.

You may trim any point between 0% and 100% along the scale. Note that one-point trimming applies an offset to the input reading, while two-point trimming applies both an offset and a gain.

Follow the steps below in order to perform input trimming.

1. Select either “1 Point” (one-point trimming) or “2 Points” (two-point trimming) by clicking the appropriate button. Each pair consists of “Set Value” and “Trim” fields.
2. Enter the values that require trimming into the “Set Value” field and click “Set”.
3. Apply the targeted signal to the input, wait until it settles and click “Trim” to capture the measured value. If you chose “2 Points”, repeat the step above for the second point.

Note:

Once you have configured all parameters, download to the unit by selecting “Download” in the Transfer dropdown menu located in the Status Bar. Or, click the  button in the Tool Bar.

You may also use the *Quick Set* feature to configure your *Input* parameters and download the settings.

Configure your parameters and click the *Quick Set* button in the window. Or, you may click the  button, located in the Tool Bar. The settings you have chosen will be applied and downloaded to your unit.

Display

Figure 22. Display Tab

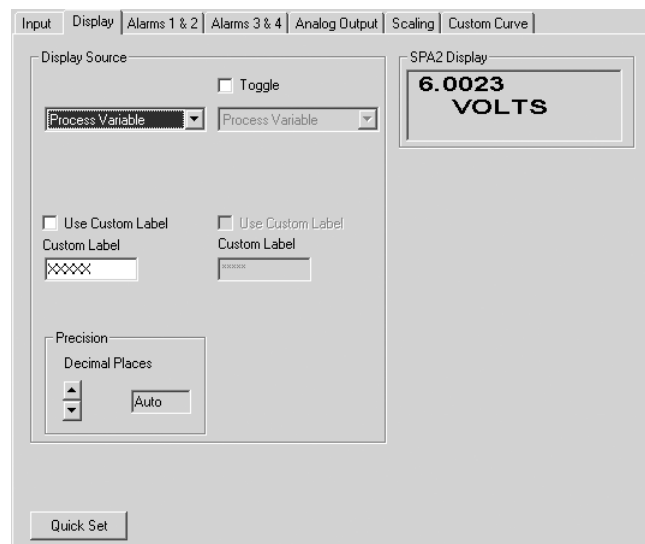

Display Source– By selecting the “Toggle” check box, you can choose to view multiple forms of your display. Your selections will toggle every few seconds to display each setting.

Toggle Mode– Every four seconds your display will toggle between two displays that you choose.

Normal Mode– Displays only your PV or AOUT value, whichever you select.

Use Custom Label– You can choose to assign a specific label, or EGU (Engineering Unit).

1. Check the “Use Custom Label” box.
2. Enter the value you wish viewed into the “Custom Label” text box.

Precision– Select the number of decimal places/ resolution of your display.

SPA² Display– Indicates the same reading as viewed on the SPA²'s LCD when the unit is in monitor mode.

Note:

Once you have configured all parameters, download to the unit by selecting “Download” in the Transfer dropdown menu located in the Status Bar. Or, click the  button in the Tool Bar.

You may also use the *Quick Set* feature to configure your *Display* parameters and download the settings.

Configure your parameters and click the *Quick Set* button in the window. Or, you may click the  button, located in the Tool Bar. The settings you have chosen will be applied and downloaded to your unit.

Alarms

Figure 23. Alarms Tab

These instructions apply to Alarms 1 through 4.

Mode– Click the appropriate button to configure your alarm as a Trip, Fault or Rate of Change alarm.

Trip– Notifies you if your process input drops below or exceeds your trip point setting.

Fault– Alerts the user of a fault whenever one has been sensed.

Rate of Change– Used if you wish to be notified when deviations occur outside of ranges you have set.

Trip Alarm

Choosing the Trip Alarm, you are prompted to complete the following fields:

Input Failure– Select this box if you choose to be notified upon breakdown of your input.

Trip Point– The reference value used for notification.

In choosing your limits you are setting the parameters for your unit to notify you if your process input drops below (Low Alarm) or exceeds (High Alarm) your trip point setting.

1. Select the “High Alarm” or “Low Alarm” button.
2. Enter the value you wish set as the trip point in the “Trip Point” text box.

Dead Band– The Dead Band is the range in which an alarm relay remains in an alarm condition even after the monitored process variable input has returned to a safe level, at or below/above the trip point setting.

3. If choosing to use a dead band value, enter it into the “Dead Band” text box

Delay– When your unit is in an alarm condition, the delay is the amount of time you set (0-120sec) to elapse before a relay trip.

4. Enter your delay time into the “Delay” text box.

Fail Safe/Non Fail Safe– A Fail Safe alarm, if in the alarm condition, will remain in the alarm condition even if power to the unit is removed. Its alarm trip relays are energized whenever the process input is in a non-alarm condition (including any dead band setting). These relays de-energize when the process input trips the alarm.

Non Fail Safe alarm trip relays are energized whenever the process input is in an alarm condition. These relays de-energize when the process input returns to the reset point (including any dead band).

5. Select a Fail Safe or Non Fail Safe alarm, and click the corresponding button.

Latching– The alarm will latch after being activated and requires a manual reset.

6. Select the “Latching” check box if you choose this alarm type.

SPA²

Programmable Current/Voltage Limit Alarm Trips

Manual Reset

A latching alarm requires a manual reset. There are two connections labeled “MR” on the SPA² top terminal block. These terminals work in conjunction with the latching alarm function.

When a SPA² is configured with latching alarms, an alarm condition will not “clear”, that is, the relay will not change state, until the input returns to a non-alarm state **AND** these manual reset terminals are shorted and then opened.

Fault Alarm

The Fault Alarm enables the fields outlined below.

1. Select the type of Fault Alarm you require in your application.

Input Failure– You are notified upon breakdown of your input.

Input Saturation– Should the input become overloaded, or saturated, your alarm would activate.

SPA Failure– Choosing this parameter activates the alarm at any internal failure that occurs.

Note:

Enabling all fault alarm configurations will activate the alarm at any failure that occurs (refer to Table 4 in the Error Codes section of this manual).

2. Select a Fail Safe or Non Fail Safe alarm, and click the corresponding button. Refer to the *Trip Alarm* section.
3. Select the “Latching” check box if you choose this alarm type. Refer to the *Trip Alarm* section.

Rate of Change Alarm

The fields below must be configured in order to set up your Rate of Change Alarm properly. The alarm will be set according to the rate of change of the process variable over a set time period.

Input Failure– Select this box if you choose to be notified upon breakdown of your input.

Delta– This is the amount by which the process variable must change. You may enter a value less than one through the PC Configuration Program only.

1. Enter your delta value in the “Delta” text box.

Delta Time– The span (1-60sec) in which the delta must change before the alarm is set.

2. Enter your time in the “Delta Time” text box.
3. Select a Fail Safe or Non Fail Safe alarm, and click the corresponding button. Refer to the *Trip Alarm* section for further explanation.
4. Select the “Latching” check box if you choose this alarm type. Refer to the *Trip Alarm* section for further explanation.

Note:

Once you have configured all parameters, download to the unit by selecting “Download” in the Transfer dropdown menu located in the Status Bar. Or, click the  button in the Tool Bar.

You may also use the *Quick Set* feature to configure your *Alarm* parameters and download the settings.

Configure your parameters and click the  button, located in the Tool Bar. The settings you have chosen will be applied and downloaded to your unit.

Analog Output

Figure 24. Analog Output (-AO) Tab

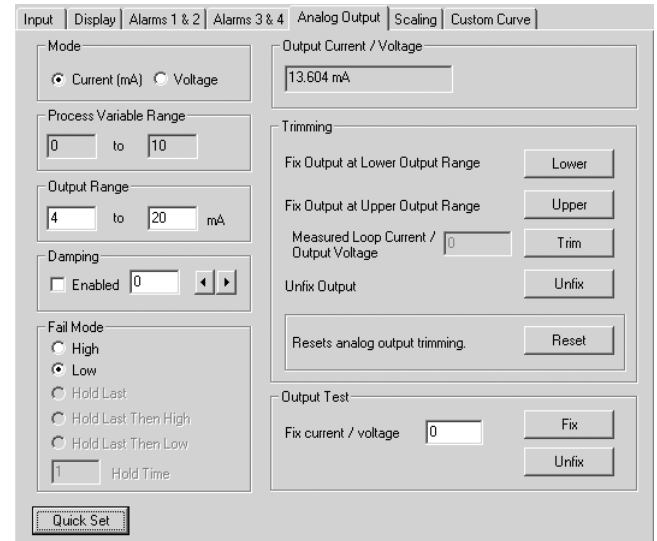

If your instrument is equipped with the -AO option, proceed with the following instructions:

Mode– Your desired output mode.

1. Select your mode, Current or Voltage.

Process Variable Range– Displays the selected process variable range in the “Measurement Mode” section of the *Input* screen.

Output Range– Sets your output limits.

2. Set your Output Range. Enter a low and high value .

Damping– Output Damping allows you to introduce a delay (0-30sec) into the response of your unit in order to stop short-lived spikes from setting off alarms.

3. Select “Enabled” if you choose to use Damping.
4. Enter your damping time into the “Damping” text box.

Fail Mode– In the case of an input failure, you have the ability to set a mode you choose to alert of the failure.

High/Low– Choosing either of these options will send the output to a High (23.6mA for current; 11.0V for voltage) or Low (3.6mA for current; -0.5V for voltage) fail mode, respectively.

5. Select your Fail Mode.

SPA²

Programmable Current/Voltage Limit Alarm Trips

Figure 25. SPA² (HLPRG) Trimming Hook-Up Diagram For PC Configuration

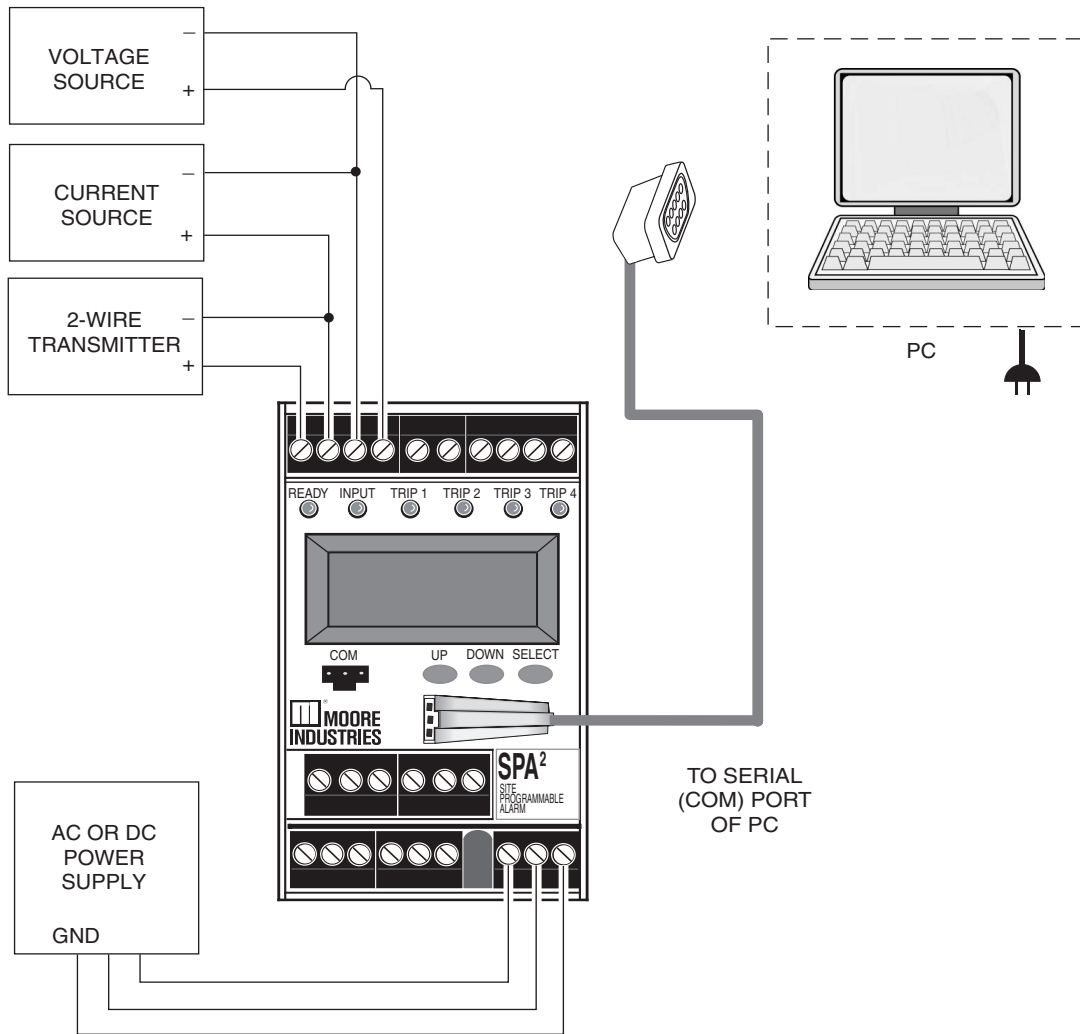

HOOK-UPS FOR OUTPUT TRIMMING

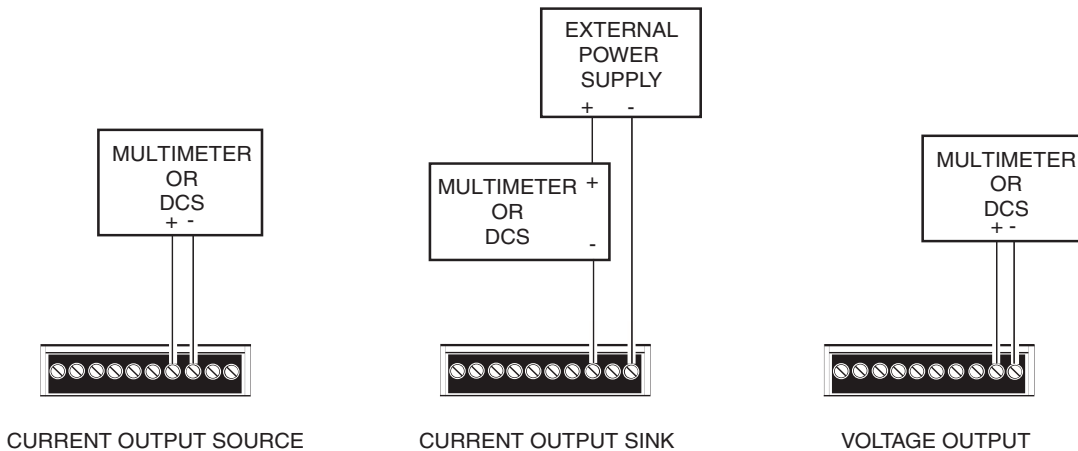

Note:

Once you have configured all parameters, download to the unit by selecting “Download” in the Transfer dropdown menu located in the Status Bar. Or, click the  button in the Tool Bar.

You may also use the *Quick Set* feature to configure your *Analog Output* parameters and download the settings.

Configure your parameters and click the *Quick Set* button in the window. Or, you may click the  button, located in the Tool Bar. The settings you have chosen will be applied and downloaded to your unit.

Output Current / Voltage– Displays the value presently at your output.

Trimming– Output Trimming increases the accuracy of your instrument by calibrating its analog output to the device that is receiving the output. This ensures that the instrument is being correctly interpreted. Refer to Figure 25 for hook-up.

1. Click the “Lower” button to trim the Lower Output Range.
2. To “fine tune” trimmed values, place the value read on the external multimeter, connected to your instrument for trimming, in the “Measured Loop Current / Output Voltage” text box and click “Trim”.
3. Click the “Upper” button and repeat Step 2 to trim the Upper Output Range.
4. Once you have performed your output trimming, click “Unfix”.

Note:

Do not click the “Reset” button in the Trimming menu unless you want to disregard your trimmed values and return to the manufacturer’s trim values.

Output Test– This test may be performed in order to check output performance and accuracy and to trim other instruments in your setup. Your output will be a current value, in mA, or a voltage equal to the value you enter into the text box. You can check the other devices on the system and calibrate them to this signal.

This feature is independent of the input. If you find that the output requires adjustment, you may perform the Trimming function.

1. Ensure that SPA² monitoring is stopped. In the “Fix current / voltage” text box, enter a value between 0-20mA (for current) or 0-10V (for voltage) and click the “Fix” button.
2. Return to monitoring the SPA². You will see the “fixed” value in the “Output Current / Voltage” display and on the external multimeter.
3. Once you have finished, click “Unfix”.

Note:

While performing Analog Output Trimming functions, you may notice a message in the “SPA 2 Status” display reading “**OUTPUT FIXED**”. Clicking the “Unfix” button will clear this message.

SPA²

Programmable Current/Voltage
Limit Alarm Trips

Scaling

Figure 26. Scaling Tab

Input | Display | Alarms 1 & 2 | Alarms 3 & 4 | Analog Output | **Scaling**

Scaling

Enabled

Input Range: Zero Full

Process Variable:

Quick Set

Note:

Using the Scaling feature will disable the Custom Curve capability. Since both are scaling features used to manipulate the appearance of your process variable, only one of these functions may be used at a time.

Scaling— This allows you to customize your display for your application. By example: if your process is sending a 4-20mA signal to the SPA² and you wish to view the input as 0-100% then this can be accomplished with the Scaling feature.

To scale your instrument, perform the following steps.

1. Click the “Enabled” check box.
2. The “Input Range” boxes (in the *Scaling Tab*) will display the range selected in the “Input Range” section of the *Input* screen.
3. In the “Process Variable” text boxes, enter the values you wish displayed when your input is at its Lower Range and Upper Range.

Once downloaded, your unit will display the scaled values on its LCD.

Note:

In our above example, you may also wish to go to the *Display* screen and click on “Use Custom Label” and enter “PCT” (percent) as your new label.

Note:

Once you have configured all parameters, download to the unit by selecting “Download” in the Transfer dropdown menu located in the Status Bar. Or, click the button in the Tool Bar.

You may also use the *Quick Set* feature to configure your *Scaling* parameters and download the settings.

Configure your parameters and click the *Quick Set* button in the window. Or, you may click the button, located in the Tool Bar. The settings you have chosen will be applied and downloaded to your unit.

Custom Curve

Figure 27. Custom Curve Tab

Input | Display | Alarms 1 & 2 | Alarms 3 & 4 | Analog Output | **Custom Curve**

Custom Curve File

Mode

Enabled

No Of Points:

Custom FV (Y) Range

Upper Range:

Lower Range:

Point	X data	Y data
1	0	0
2	2	3
3	4	6
4	6	7
5	8	9
6	10	10

Quick Set

Note:

Using the Custom Curve feature will disable the Scaling capability. Since both are scaling features used to manipulate the appearance of your process variable, only one of these functions may be used at a time.

Custom Curve—The Custom Curve feature allows you to set up your own custom curve table. This allows you to tell the transmitter what it should output when it receives a certain input. This feature also allows you the ability to write a table in Microsoft® Excel, save it in a .csv format, and import it into the Configuration Software. This makes it simple to save the custom table for downloading to multiple units or for backup purposes.

To create a custom curve:

1. Click the “Enabled” box .
2. Select the number of points for your curve (128 points maximum) and enter it into the “No Of Points” text box.
3. In the “Custom PV (Y) Range” text boxes, enter the values you wish displayed when your input is at its upper and lower ranges.
4. Type your individual values in the X and Y columns. Source variables are inserted into the X Column while the corresponding data is inserted into the Y Column.
5. After all of your data has been entered, you must use the *Custom Curve* dropdown menu to save your newly created custom table (“Save Custom Curve”) and to download it to your SPA² (“Download Custom Curve”). See Figure 28.

Note:

Once you have configured all parameters, download to the unit by selecting “Download” in the Transfer dropdown menu located in the Status Bar. Or, click the  button in the Tool Bar.

You may also use the *Quick Set* feature to configure your *Custom Curve* parameters and download the settings.

Configure your parameters and click the *Quick Set* button in the window.

Note:

When the *Custom Curve* feature is enabled for your unit, the SPA² will display “CC” in the lower left corner of its LCD.

Figure 28. Custom Curve Dropdown Menu

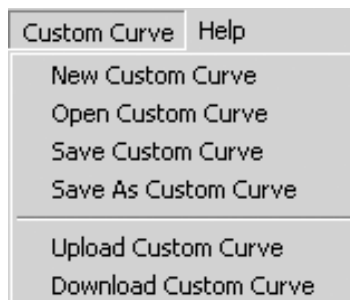

SPA²

Programmable Current/Voltage Limit Alarm Trips

Error Codes

Every SPA² is subjected to an exhaustive battery of operational checks and tests prior to its shipment. Occasionally, however, units can sustain damage getting from the factory to the user.

As a safeguard, your unit is equipped with a full set of internal diagnostics that check operation and configuration upon power-up. If there are problems with

the microprocessor, or with conflicting operating parameter settings, the LCD will display an error code upon unit start-up.

Table 4 lists the error codes.

For most of these problems, it will be necessary to return the instrument to the factory.

Table 4. SPA² (HLPRG) LCD Error Codes

Error Message	What it Means	What to Do
*ERROR HWARE	Hardware failure	Cycle power to the unit, and if the error occurs again, return the unit to the factory for service.
*ERROR EEROM	EEPROM Error - The internal processor failed	
*ERROR CALIB	Calibration data bad - The factory-set calibration of the unit has failed to initialize	
*ERROR CKSUM	Configuration or calibration data checksum mismatch	
*ERROR BLANK	EEPROM blank	
ERROR RANGE	Process variable out of range (<-99999 or >+99999)	Check input signal to ensure that it is within sensor limits.
*ERROR DZERO	Maths division by zero error	Cycle power and download configuration data. If the error occurs again, return the unit to the factory for service.
*ERROR CONFG	Configuration information bad	Cycle power to the unit, then run through the configuration menus to ensure that the technician made the correct sensor selections, range settings, etc.
*ERROR SWARE	Software watchdog failure	Cycle power to the unit. If the error occurs again, return the unit to the factory for service.
RJC BROKE	Reference Junction Compensation Resistor Burnout	Cycle power to the unit. If the error occurs again, return the unit to the factory for service.
ERROR INSAT	Input saturation condition (reaches 110% of calibrated range)	Check input signal to ensure that it is within sensor limits.
ERROR INPUT	Input error condition	Check input signal to ensure that it is within sensor limits.
ERROR	Other or combination of errors	Cycle power to the unit. If the error occurs again, return the unit to the factory for service.
WIRE 1 BROKE	Wire 1 broken	Check your system for a broken wire(s). Fasten any loose wiring; replace broken wires.
WIRE 2 BROKE	Wire 2 broken	
WIRE 3 BROKE	Wire 3 broken	
WIRES BROKE	Wire 4 broken or more than one wire broken	

*This will induce a "SPA Failure" condition in a configured Fault Alarm.

Installation

Installation consists of physically mounting the unit and completing the electrical connections.

Mounting

The SPA² is housed in a “universal” DIN case that can be mounted on both 35mm G-type (EN50035) and 35mm Top-Hat (EN50022) DIN-rail.

To mount the SPA² on a Top-Hat DIN-rail, seat the upper extrusion on the unit back panel over the top lip of the rail and pivot downward until the housing locks into place.

To mount the unit on a G-type rail, seat the extrusion under the top lip of the rail and again, pivot downward.

When mounting multiple units, like a rack or cabinet, make sure to allow adequate vertical spacing for pivoting the units.

Making the Electrical Connections

Refer to Figure 3 (SPA² Front Panel Configuration) or Figure 19 (SPA² PC Configuration) for electrical connections.

Recommended Ground Wiring Practices

Moore Industries recommends the following ground wiring practices:

- Any Moore Industries product in a metal case or housing should be grounded.
- The protective earth conductor must be connected to a system safety earth ground before making any other connections.
- All input signals to, and output signals from, Moore Industries' products should be wired using a shielded, twisted pair technique. Shields are to be connected to an earth or safety ground at the unit itself.
- The maximum length of unshielded input and/or output signal wiring should be two inches.

CE Conformity

Installation of any Moore Industries' products that carry the CE certification **must** adhere to the guidelines as stated in order to meet the requirements set forth in the European EMC and Low Voltage Directives (EN 61326 and EN 61010). Consult the factory for the most current information on products that have been CE certified.

Operation

Once programmed, calibrated, installed, and supplied with the correct power, the SPA² alarm begins to operate immediately. Depending upon environmental conditions, it can be expected to operate unattended for extended periods of time.

Maintenance

Moore Industries suggests a quick check for terminal tightness and general unit condition every 6-8 months. Always adhere to any site requirements for programmed maintenance.

Customer Support

Moore Industries is recognized as the industry leader in delivering top quality to its customers in products and services. We perform a battery of stringent quality assurance checks on every unit we ship. If any Moore Industries product fails to perform up to rated specifications, call us for help. Our highly skilled staff of trained technicians and engineers pride themselves on their ability to provide timely, accurate, and practical answers to your process instrumentation questions.

Factory phone numbers are listed on the back cover of this manual.

If problems involve a particular SPA², there are several pieces of information that can be gathered **before you call the factory** that will help our staff get the answers you need **in the shortest time possible**. For fastest service, gather the complete model and serial number(s) of the problem unit(s) and the job number of the original sale.



Declaration of Conformity



EMC Directive 89/336/EEC

- **Manufacturer's Name:** Moore Industries-International, Inc.
- **Manufacturer's Address:** 16650 Schoenborn Street
North Hills, CA 91343-6196
USA

Declares that the product(s):

- **Product Name:** SPA²

MODEL	INPUT	OUTPUT	POWER	OPTIONS	HOUSING
-------	-------	--------	-------	---------	---------

- **Model Number(s):** SPA² * * * * *

* Indicates any input, output, option and housing as stated on the product data sheet.

• Conforms to the following EMC specifications:

- EN 61326-1, 1998, Electromagnetic Compatibility requirements for electrical equipment for control use.
- EN 61010-1, 1995, Safety requirements for electrical equipment for measurement and control use.

• Supplementary Information:

None

June 8, 2004

Date

Fred Adt

Quality Assurance Director

Robert Stockham

Moore Industries-Europe General Mgr.

European Contact: Your Local Moore Industries Sales and Service Office



The Interface Solution Experts • www.miinet.com

United States • info@miinet.com
 Tel: (818) 894-7111 • FAX: (818) 891-2816
 Australia • sales@mooreind.com.au
 Tel: (02) 8536-7200 • FAX: (02) 9525-7296

Belgium • info@mooreind.be
 Tel: 03/448.10.18 • FAX: 03/440.17.97
 The Netherlands • sales@mooreind.nl
 Tel: (0)344-617971 • FAX: (0)344-615920

China • sales@mooreind.sh.cn
 Tel: 86-21-62481120 • FAX: 86-21-62490635
 United Kingdom • sales@mooreind.com
 Tel: 01293 514488 • FAX: 01293 536852

RETURN PROCEDURES

To return equipment to Moore Industries for repair, follow these four steps:

1. Call Moore Industries and request a Returned Material Authorization (RMA) number.

Warranty Repair –

If you are unsure if your unit is still under warranty, we can use the unit's serial number to verify the warranty status for you over the phone. Be sure to include the RMA number on all documentation.

Non-Warranty Repair –

If your unit is out of warranty, be prepared to give us a Purchase Order number when you call. In most cases, we will be able to quote you the repair costs at that time. The repair price you are quoted will be a "Not To Exceed" price, which means that the actual repair costs may be less than the quote. Be sure to include the RMA number on all documentation.

2. Provide us with the following documentation:
 - a) A note listing the symptoms that indicate the unit needs repair
 - b) Complete shipping information for return of the equipment after repair
 - c) The name and phone number of the person to contact if questions arise at the factory
3. Use sufficient packing material and carefully pack the equipment in a sturdy shipping container.
4. Ship the equipment to the Moore Industries location nearest you.

The returned equipment will be inspected and tested at the factory. A Moore Industries representative will contact the person designated on your documentation if more information is needed. The repaired equipment, or its replacement, will be returned to you in accordance with the shipping instructions furnished in your documentation.

WARRANTY DISCLAIMER

THE COMPANY MAKES NO EXPRESS, IMPLIED OR STATUTORY WARRANTIES (INCLUDING ANY WARRANTY OF MERCHANTABILITY OR OF FITNESS FOR A PARTICULAR PURPOSE) WITH RESPECT TO ANY GOODS OR SERVICES SOLD BY THE COMPANY. THE COMPANY DISCLAIMS ALL WARRANTIES ARISING FROM ANY COURSE OF DEALING OR TRADE USAGE, AND ANY BUYER OF GOODS OR SERVICES FROM THE COMPANY ACKNOWLEDGES THAT THERE ARE NO WARRANTIES IMPLIED BY CUSTOM OR USAGE IN THE TRADE OF THE BUYER AND OF THE COMPANY, AND THAT ANY PRIOR DEALINGS OF THE BUYER WITH THE COMPANY DO NOT IMPLY THAT THE COMPANY WARRANTS THE GOODS OR SERVICES IN ANY WAY.

ANY BUYER OF GOODS OR SERVICES FROM THE COMPANY AGREES WITH THE COMPANY THAT THE SOLE AND EXCLUSIVE REMEDIES FOR BREACH OF ANY WARRANTY CONCERNING THE GOODS OR SERVICES SHALL BE FOR THE COMPANY, AT ITS OPTION, TO REPAIR OR REPLACE THE GOODS OR SERVICES OR REFUND THE PURCHASE PRICE. THE COMPANY SHALL IN NO EVENT BE LIABLE FOR ANY CONSEQUENTIAL OR INCIDENTAL DAMAGES EVEN IF THE COMPANY FAILS IN ANY ATTEMPT TO REMEDY DEFECTS IN THE GOODS OR SERVICES, BUT IN SUCH CASE THE BUYER SHALL BE ENTITLED TO NO MORE THAN A REFUND OF ALL MONIES PAID TO THE COMPANY BY THE BUYER FOR PURCHASE OF THE GOODS OR SERVICES.

ANY CAUSE OF ACTION FOR BREACH OF ANY WARRANTY BY THE COMPANY SHALL BE BARRED UNLESS THE COMPANY RECEIVES FROM THE BUYER A WRITTEN NOTICE OF THE ALLEGED DEFECT OR BREACH WITHIN TEN DAYS FROM THE EARLIEST DATE ON WHICH THE BUYER COULD REASONABLY HAVE DISCOVERED THE ALLEGED DEFECT OR BREACH, AND NO ACTION FOR THE BREACH OF ANY WARRANTY SHALL BE COMMENCED BY THE BUYER ANY LATER THAN TWELVE MONTHS FROM THE EARLIEST DATE ON WHICH THE BUYER COULD REASONABLY HAVE DISCOVERED THE ALLEGED DEFECT OR BREACH.

RETURN POLICY

For a period of thirty-six (36) months from the date of shipment, and under normal conditions of use and service, Moore Industries ("The Company") will at its option replace, repair or refund the purchase price for any of its manufactured products found, upon return to the Company (transportation charges prepaid and otherwise in accordance with the return procedures established by The Company), to be defective in material or workmanship. This policy extends to the original Buyer only and not to Buyer's customers or the users of Buyer's products, unless Buyer is an engineering contractor in which case the policy shall extend to Buyer's immediate customer only. This policy shall not apply if the product has been subject to alteration, misuse, accident, neglect or improper application, installation, or operation. THE COMPANY SHALL IN NO EVENT BE LIABLE FOR ANY INCIDENTAL OR CONSEQUENTIAL DAMAGES.



United States • info@miinet.com
Tel: (818) 894-7111 • FAX: (818) 891-2816
Australia • sales@mooreind.com.au
Tel: (02) 8536-7200 • FAX: (02) 9525-7296

Belgium • info@mooreind.be
Tel: 03/448.10.18 • FAX: 03/440.17.97
The Netherlands • sales@mooreind.nl
Tel: (0)344-617971 • FAX: (0)344-615920

China • sales@mooreind.sh.cn
Tel: 86-21-62481120 • FAX: 86-21-62490635
United Kingdom • sales@mooreind.com
Tel: 01293 514488 • FAX: 01293 536852

The Interface Solution Experts • www.miinet.com