

*Smart HART® Loop
Interface and Monitor*



HIM

Table of Contents

The HIM	3
About this Manual	3
Specifications	4
Configuring the HIM	5
Installing the HIM	6
Installing the HIM into the Loop	6
Bench Checking the HIM	8
PC Configuration Software.....	10
Programming the HART Parameters	11
Programming the Display Parameters	12
Programming the Alarms Parameters	13
Programming the Analog Outputs Parameters	15
Programming the Custom Curve Parameters.....	15
Programming the Scaling Parameters	16
Programming the Trimming Parameters	17
Customer Service	18
Appendix A: Using the HIM MODBUS Feature	19

The HIM

The Moore Industries HIM HART Interface Module unlocks the full potential of new and in-place HART multivariable transmitters, valves, meters, and other smart instruments.

Converts HART to 4-20mA Signals

The HIM allows up to three additional analog process variable measurements from a multivariable transmitter or valve with no additional process penetrations. Installed transparently across the 4-20mA instrument loop, the HIM reads the HART digital process data that rides on the loop wires. It converts the digital information for up to three isolated analog (4-20mA) process signals that are readily accepted by in-place control systems, such as a DCS or PLC.

Provides Process and Diagnostic Alarms

Relay alarm trips (optional) can be individually user-set either to trip when unwanted high/low process conditions occur, or provide a diagnostic health warning to alert of loop or instrument fault conditions.

Takes Advantage of Legacy Instruments

The device lets you leave existing smart HART transmitters and valves in place, yet still take advantage of all the information they have to offer.

Works with every Smart HART Device

The instrument can be programmed in minutes to interface with every HART-compatible monitoring and control device.

About this Manual

Wherever you see a **Note**, **Caution**, or **WARNING** pay particular attention.

- A **Note** provides information to help you in avoiding minor inconveniences during calibration, installation, or operation of the HIM.
- A **Caution** provides information on steps to take to avoid procedures and practices that could risk damage to the HIM or other equipment.
- A **WARNING** provides information on steps to take to avoid procedures and practices that could pose safety risks to personnel.

Figure 1. The HIM accepts a digital HART signal and outputs both analog signals and alarm relays

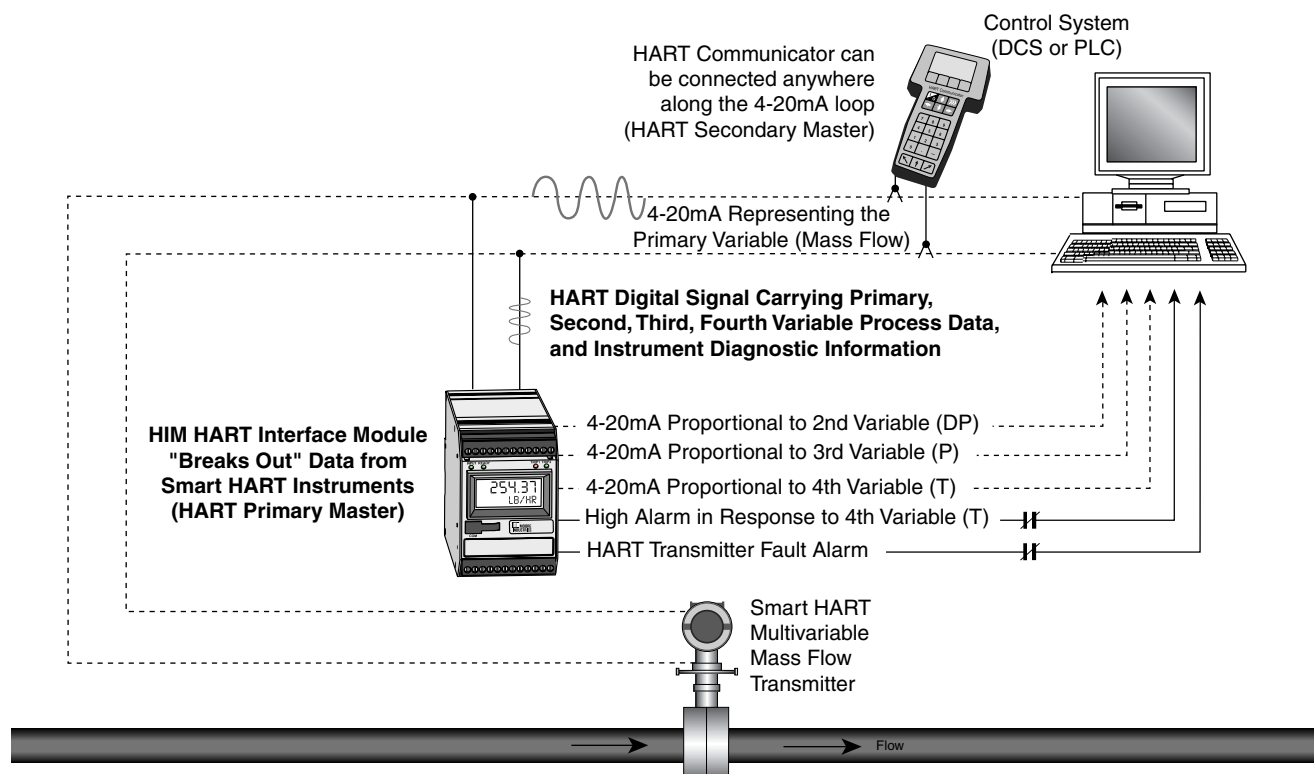

Specifications

<p>Performance Input Accuracy: Reflects the accuracy of the HART field device Input Impedance: Transmit Mode: 150 ohms; Receive Mode: Less than 5K ohms Input Over-Range Protection: ±5Vdc</p> <p>ANALOG OUTPUTS Output Accuracy: ±0.015% of maximum output span (20mA). Includes the combined effects of linearity, hysteresis, repeatability and adjustment resolution) Output Response Time: <120ms, 10-90% Isolation: 500Vrms channel-to-channel isolation; 1000Vrms between case, input, outputs and power terminals, and will withstand 1500Vac dielectric strength test for one minute with no breakdown Ripple: Less than 10mV peak-to-peak when measured across a 250 ohm resistor Output Limiting: 130% of span maximum; 125% of span typical Output Protection: Transient protection on output Load Capability: 0-20mA, 1100 ohms max. Load Effect: ±0.01% of span from 0 to maximum load resistance Line Voltage Effect: ±0.005% of output span for a 1% change in line voltage Input Fail Modes: PC programmable to fail high, fail low, hold last, hold last then fail high, or hold last then fail low (configurable hold time, 0-60 seconds) Output Limits on Input Failure: 0-20mA: Fail Low to 0mA or Fail High to 23.6mA 4-20mA: Fail Low to 3.6mA or Fail High to 23.6mA X-20mA (0<X<4): Fail Low</p>	<p>Performance (Continued) to 90% of XmA or Fail High to 23.6mA +TX Power Supply: 23.2Vdc ±3%</p> <p>ALARM OUTPUTS Digital Response Time: Defined by HART protocol as 500 millisecond max. in Normal HART Mode; 333 milliseconds maximum in HART Burst Mode Alarm Response Time: Digital Response Time + 150 milliseconds (Defined as time from the field instrument's reporting a fault until the HIM alarm is tripped) Alarm Trip Delay: Programmable from 0-120 seconds</p> <p>MODBUS OUTPUTS Type: Standard MODBUS RTU protocol interface over RS485 (parameters as specified in U.S. Standard EIA-RS485) Address Range: Configurable from 1 to 247. Unit will assume a MODBUS address of 01 by default Baud Rate: Interface supports the following: 300, 600, 1200, 4800, 9600, 19.2K. MODBUS interface will support even, odd and no parities. Unit will assume a baud rate of 9600 and no parity by default Character Format: One start bit, 8 data bits and one stop bit Data Format: User-selectable Standard LSW (Least Significant Word) or Swapped MSW (Most Significant Word). Unit will assume Standard LSW by default</p> <p>Power Consumption: 2-3.5W, nominal; 4.5W @24Vdc max. for units using transmitter excitation to supply loop power a 2-wire instrument</p> <p>Indicators LCD Type: Two-line LCD; Top Row, 10mm (0.4 inch) high black digits on a reflective background; Bottom Row,</p>	<p>Indicators (Continued) 6mm (0.225 inch) high digits on a reflective background; two-digit HART address indicator Format: Top row is five alphanumeric characters, plus sign and decimal point; bottom row is five alphanumeric characters Decimal Points: User-selectable for 0, 1, 2, or 3 places after the decimal point or automatically adjusting with a four decimal point maximum Range: -99999 to 99999 Min. Display Span: 1.00 Display Update Rate: 100msec LED Type: Dual color red/green indicate: INPUT LED: Whether (green) or not (red) the HART input is connected and functioning properly READY LED: Whether (green) or not (red) the HIM is initialized and operating properly TRIP 1 and 2 LED: Shows the status of alarm off (green) or alarm on (red)</p> <p>Ambient Operating & Storage Conditions Range: -40°C to +85°C (-40°F to +185°F) Display Range: -25°C to +85°C (-13°F to +185°F) Relay Range: -25°C to +70°C (-13°F to +158°F) Relative Humidity: 0-95%, non-condensing Ambient Temperature Effect: ±0.0065% of span/°C maximum RFI/EMI Immunity (Standard): 20V/m@20-1000MHz, 1KHz AM, when tested according to IEC1000-4-3-1995 RFI/EMI Immunity (with -RF Option): 30V/m@ 20-1000MHz, 1KHz, when tested according to IEC1000-4-3-1995 Noise Rejection: Common Mode: 100dB@ 50/60Hz</p> <p>Weight 567 grams (16 ounces)</p>
--	---	--

Specifications and information subject to change without notice.

Configuring the HIM

One of the benefits of the HIM is that there are no internal or external controls to adjust or settings to change. All operating parameters are set using the PC Configuration software.

Once these software settings are made, they are downloaded to the monitor in the form of a Configuration File and stored in the unit's nonvolatile memory. You can choose to save a backup copy of the file on your PC hard drive or diskette. The HIM communicates with the PC through a proprietary communications cable to the PC's serial (COM) port.

Begin by installing the PC Configuration Software.

Installing the PC Configuration Software

Refer to Table 1 for the equipment needed.

1. Insert the diskette labeled *HIM Installation Disk One* into the disk drive of the PC.
2. In Windows® 95/98/2000/ME/NT, go to the *Start* menu, and access *Settings*, then *Control Panel*, and finally *Add/Remove Programs*.
3. Click *Install* and follow the instructions on the screen.

Table 1. Assembling the necessary equipment.

Device	Specifications
Precision Load Resistor	250 ohms, ±0.01%
Multimeter or Ammeter	Accurate to ±0.009% of span; e.g., HP Model 3487A
Power Supply	24Vdc, ±10%
Personal Computer	80386-based(or faster) IBM PC, or 100% compatible; (Pentium recommended) 1.44Mb floppy diskette drive 4Mb free RAM; 16Mb recommended 20Mb free disk space on hard drive 1 (one) serial port (COM 1, 2, 3, or 4)
PC Operating System	Microsoft Windows® 95, 98, 2000, ME, or NT with Internet Explorer 4.0+ <i>or</i> Microsoft Windows® NT with Service Pack 3 or greater
Moore Industries PC Configuration Software	Version 1.0 or higher, successfully installed to the hard drive
Communication Cable	Part# 803-053-26, or equivalent

Once the Configuration Program is installed on the PC, the unit can be connected either into the loop or to test equipment to simulate input and monitor output. With the PC program, the user can then view and/or change its operating parameters. To begin the process, connect the HIM either into the loop (see *Installing the HIM into the Loop* on page 6) or into a configuration setup (see *Bench Checking the HIM* on page 8).

HIM

Smart HART® Loop
Interface and Monitor

Installing the HIM

There are two methods for connecting the HIM for configuration. The recommended method requires you to install the instrument into the loop before you program it. The secondary method allows you to bench check the HIM by attaching it to test equipment that will simulate the input and monitor the output.

Installing the HIM into the Loop

Installation consists of physically mounting the unit, grounding the instrument, and completing the electrical connections. To install the HIM into the loop for configuration, use the equipment in Table 1 to hookup the HIM into the loop as shown in Figure 2 (without using the HIM to power a transmitter) or Figure 3 (using the TX terminal to power a transmitter). If you need a complete terminal description, see Table 2, page 9.

Mounting

The HIM is designed to snap easily onto 32mm, G-type (EN50035) or 35mm Top Hat (EN50022) DIN rails.

Electrical Connections

After mounting, you are ready to connect the HIM to the loop. Each unit comes equipped with a transmitter excitation terminal which allows it to supply power to the monitored HART instrument, if necessary. Figures 2 and 3 show the connection diagrams for an HIM with or without using the transmitter excitation current.

CE Conformity

Installation of any Moore Industries' products that carry the CE certification (Commission Electrotechnique) **must** adhere to the guidelines in *Installing the HIM* in order to meet the requirements set forth in applicable

Figure 2. Installing a HIM into the loop without using the Transmitter Excitation (+TX) terminal

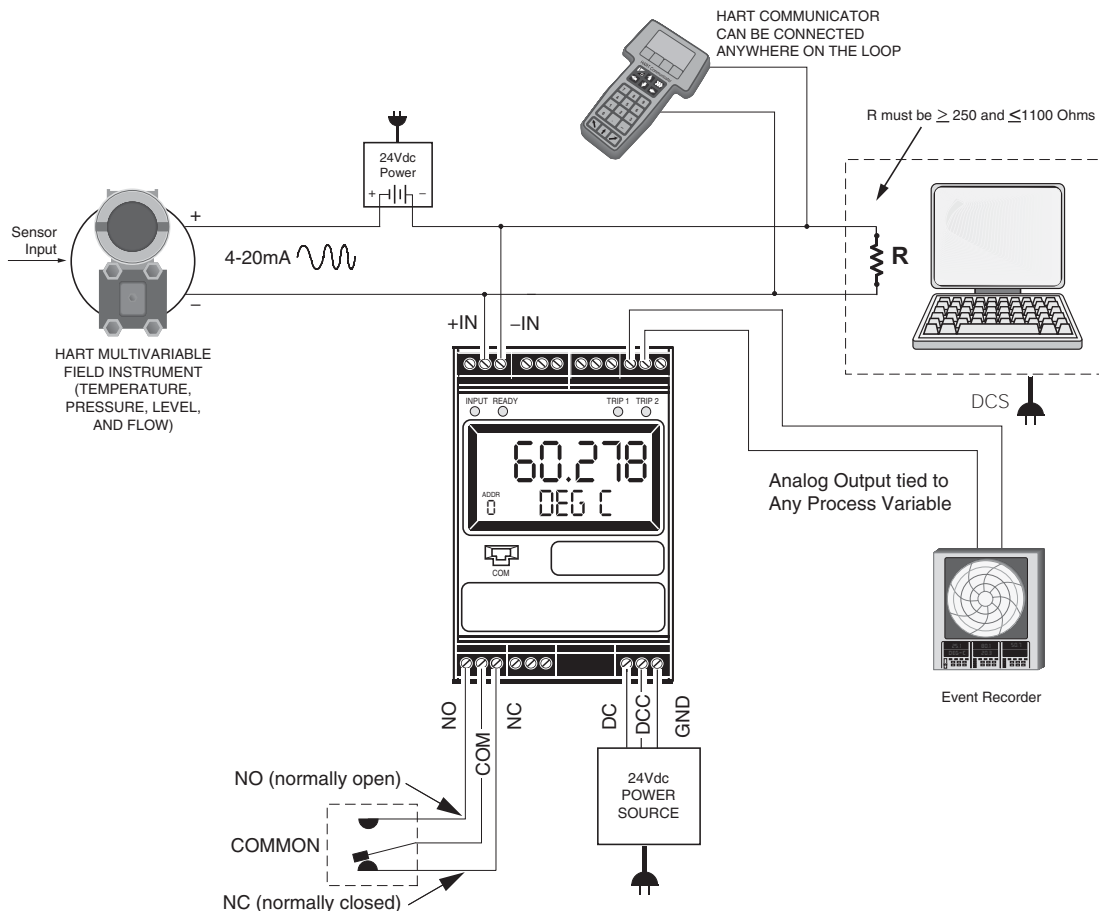

EMC (Electromagnetic Compatibility) directives (EN55011, EN 50082-1, EN50082-2, etc.) Consult the factory for the most current information on products that have been CE certified.

Recommended Ground Wiring Practices

Moore Industries recommends the following ground wiring practices:

- Any Moore Industries product in a metal case or housing should be grounded.
- The protective earth conductor must be connected to a system safety earth ground before making any other connections.

• All input signals to, and output signals from, Moore Industries' products should be wired using a shielded, twisted pair technique. Shields are to be connected to an earth or safety ground at the unit itself.

• The maximum length of unshielded input and output signal wiring should be 2 inches.

Power Sourcing Parameters for General Locations, Intrinsically Safe, and Non-Incendive/Type N applications

In accordance with IEC 1010.1 Annex H (all models), the input terminals must be connected to and/or supplied from a certified energy limiting Class 2 or a Separate Extra Low Voltage (S.E.L.V.) power supply separated from all mains by double/reinforced insulation.

Figure 3. Installing a HIM into the loop using the Transmitter Excitation (+TX) terminal

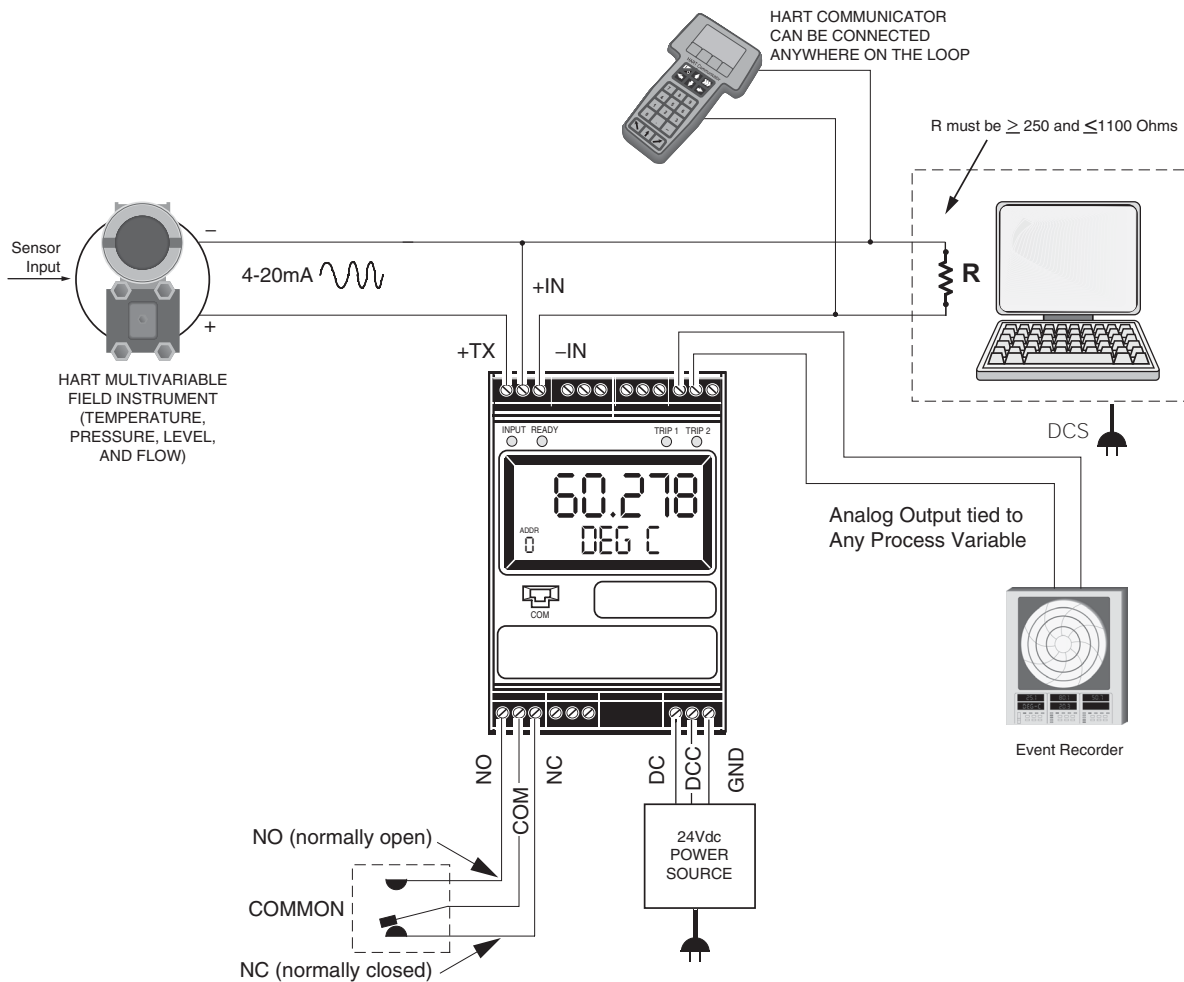

HIM

Smart HART® Loop
Interface and Monitor

Bench Checking the HIM

If you would like to configure the HIM before attaching it to the loop, you need to hook it up with the equipment listed in Table 1. Refer to Figures 4 and 5 for instructions on how to bench check the HIM either with or without taking advantage of the Transmitter Excitation (+TX) terminal. If you need further descriptions of the terminals, see Table 1, page 9.

Figure 4. Bench checking the HIM using the Transmitter Excitation (+TX) terminal to power a transmitter

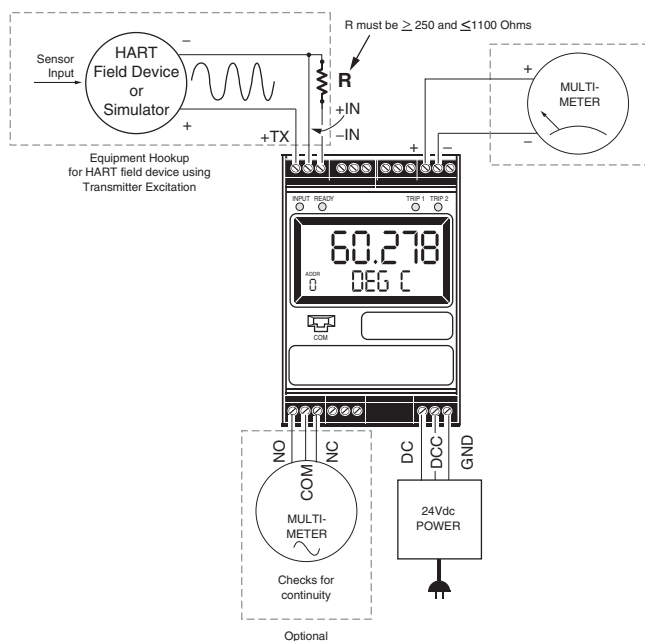

Figure 5. Bench checking the HIM without using the Transmitter Excitation (+TX) terminal to power a transmitter

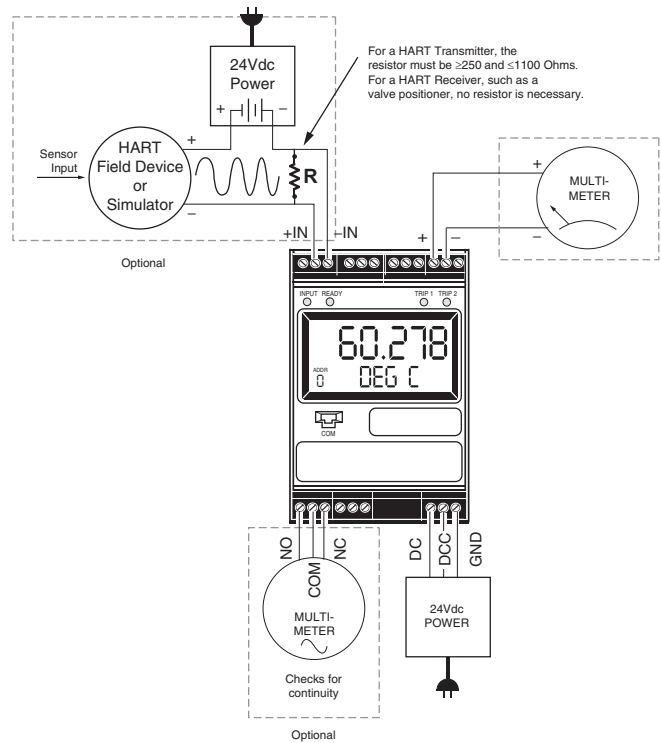

Table 2. Terminal Designations.

INPUT / OUTPUT	T1	T2	T3	T4	T5	T6	T7	T8	T9	T10	T11	T12
HART Input, 2 Analog Outputs (2AO)	+TX	+IN	-IN	No Label			+I Source (AO2)	-I Source or +I Sink (AO2)	-I Sink (AO2)	+I Source (AO1)	-I Source or +I Sink (AO1)	-I Sink (AO1)
HART Input, 3 Analog Outputs (3AO)	+TX	+IN	-IN	+I Source (AO3)	-I Source or +I Sink (AO3)	-I Sink (AO3)	+I Source (AO2)	-I Source or +I Sink (AO2)	-I Sink (AO2)	+I Source (AO1)	-I Source or +I Sink (AO1)	-I Sink (AO1)
HART Input, 2 MODBUS Oututs and 1 Analog Output (MB1AO)	+TX	+IN	-IN	+I Source (AO)	-I Source or +I Sink (AO)	-I Sink (AO)	A MODBUS 2	B MODBUS 2	S MODBUS 2	A MODBUS 1	B MODBUS 1	S MODBUS 1
HART Input, 2 MODBUS Outputs (MB)	+TX	+IN	-IN	No Label			A MODBUS 2	B MODBUS 2	S MODBUS 2	A MODBUS 1	B MODBUS 1	S MODBUS 1
ALARM RELAYS / POWER	B1	B2	B3	B4	B5	B6	B7	B8	B9	B10	B11	B12
No Alarm	No Label						No Label			DC	DCC	Ground
Single Alarm (-1PRG)	NO1	CM1	NC1	NO2	CM2	NC2	No Label			DC	DCC	Ground
Relay 1												
Dual Alarm (-2PRG)	NO1	CM1	NC1	NO2	CM2	NC2				DC	DCC	Ground
Relay 2												

KEY:

+IN/-IN = Current input into HIM from HART device +/- Source = Analog Source Output A/B = MODBUS Output NC/NC# = Normally Closed DC/DCC = 24VDC Connection	+TX = Transmitter Excitation Current +/- Sink = Analog Sink Output NO/NO# = Normally Open CM/CM# = Common (AO#) = Analog Output
--	---

Note: The standard Single Alarm unit (1PRG) utilizes a DPDT relay.

Terminal Position and Sensor Hook-Up Guides

**TOP (T)
TERMINALS**

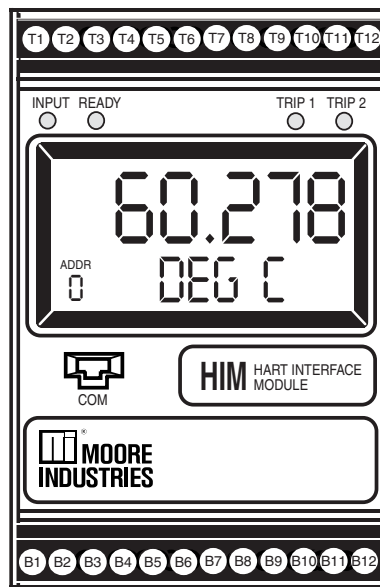

**BOTTOM (B)
TERMINALS**

HIM

Smart HART® Loop Interface and Monitor

Figure 6. All of the HIM Operating Parameters can be configured from the Main Screen of the Configuration Program.

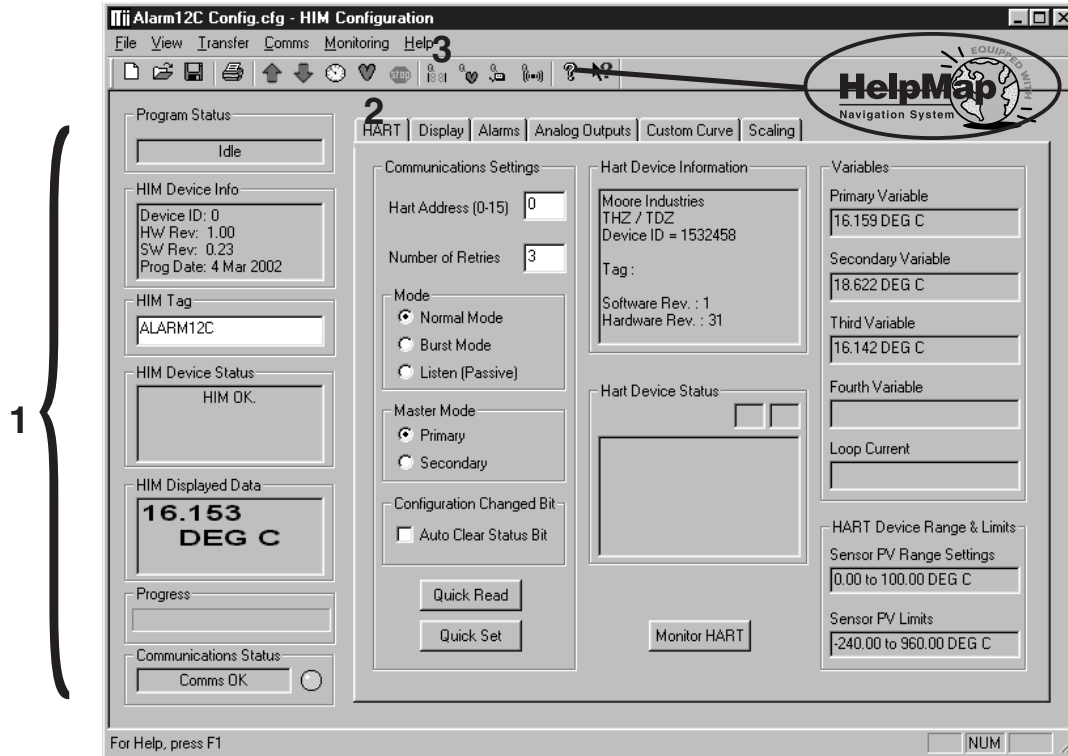

PC Configuration Software

The HIM PC Configuration Software can be used to program all of the HIM's parameters. For detailed information on how to use our configuration software, access our HelpMap Navigation System by opening the Configuration Software and clicking on the yellow question mark in the top-middle of the screen.

The PC Software is composed of these sections:

1. **HIM Status & Information Section**—The left side of the screen includes seven boxes that display the different settings of the attached HIM.

Program Status—Displays the activity of the connected HIM. It will show you if the unit is *Idle*, *Uploading*, *Downloading*, *Monitoring*, or *Searching*.

HIM Device Info—Displays the individual characteristics of the attached HIM, such as its Identity, Hardware and Software Revisions, and the last date that the device was configured.

HIM Tag—A phrase used to identify a HIM.

HIM Device Status—displays how the HIM is functioning, giving a brief summary of any errors or displaying *OK* if it is operating normally.

HIM Displayed Data—this display mirrors what the attached HIM is displaying.

Progress—this bar stays in motion any time the HIM is monitoring, uploading, or downloading.

Communication Status—monitors the PC Software's ability to communicate with the HIM.

2. **HART/Display/ Alarms/Analog Outputs/Custom Curve/ Scaling Tabs**—These tabs change the right side of the screen to allow you to set the appropriate part of the HIM's configuration. See pages 11-17 for additional information on these tabs.
3. **File Menu & Toolbar**—Allows you to assign an identifying phrase to an individual HIM.



—For detailed information on any HIM-related topic, access the HelpMap Navigation System by clicking on the question mark button.

Programming the HART Parameters

The PC program allows you to configure the HIM by using six simple menus. The first of the menus—the HART menu—sets the HART communications parameters and displays a wide variety of HART parameters. It is shown in Figure 6, page 10.

To program the HART parameters, change the settings in the *Communications Settings* box, then press *Quick Set*. See the descriptions below of the various sections of the screen.

HART Address

The *HART Address* is the address of the HART device that the HIM will be monitoring.

Number of Retries

The *Number of Retries* can be set between 1 and 9, and will determine how many times the HIM will attempt to poll the HART transmitter (without success), before it indicates a HART Fault condition.

Normal/Burst/Listen Modes

The HIM can operate in one of three modes: *Normal*, *Burst*, or *Listen*. In each of these modes, the HIM attempts to find a HART transmitter.

In *Normal* mode, the HIM polls the HART loop for a transmitter, then polls the HART instrument twice per second, requesting the current process status and the HART instrument's diagnostic status. The HART instrument responds with the requested data.

In *Burst* mode, the monitored HART instrument is programmed to continuously transmit its process variable and health status. The HIM samples the continuous HART data three times per second.

Listen mode allows the HIM to operate on a loop that already has primary and secondary HART masters. In *Listen* mode, the monitor connects passively, continuously sampling HART data from a smart instrument without affecting normal loop operation. When using this mode, either the monitored smart HART instrument must be set in Burst Mode or a HART master must be continuously polling the smart HART slave device.

The HART protocol allows for two communications masters on the loop, a Primary and a Secondary. Setting the HIM to function as the Primary HART Master in the application means that any other HART device in the loop must be configured either as a HART Secondary Master (1 per loop) or as a HART Slave (up to 16 per loop). Conversely, setting the HIM to function as the Secondary HART Master allows other HART devices to function either as a Primary Master or as Slaves. Configuring more than one device on a single loop as a Primary or Secondary HART Master will cause a communications failure.

Auto Clear Status Bit

Most HART instruments indicate when a device's configuration has been changed. This indication (status bit) can be reset by sending HART command 38—reset configuration changed. Checking the *Auto Clear Status Bit* box causes the HIM to issue this command whenever the HART instrument it is monitoring has its configuration changed. However, the HIM can also be set to alarm on this bit (see *Programming the Alarm Parameters*). If the HIM is both set to alarm and to auto clear, then it will do both—going into alarm mode and resetting that indication.

Quick Read/Set

The *Quick Read* button causes the PC Configuration Software to read the communications information from the attached HIM; the *Quick Set* button causes the software to configure the HIM's communications settings to match those of the PC Software.

HART Device Info

This box displays the identification and revision information of the monitored HART instrument.

HART Device Status

The HART Device Status box displays the current status of the monitored HART transmitter. In a small double-box, the software displays the code (hex number) associated with the status.

Variables

The device will monitor up to the first four HART variables sent by your transmitter. This portion of the screen displays those variables and the Loop Current.

HART Device Range & Limits

This portion of the screen displays the range and the sensor limits of the monitored HART transmitter.

Programming the Display Parameters

The *Display* tab configures the HIM's LCD display. To program the Display parameters, change the settings in the *Display Source* box, then press *Quick Set*. See the descriptions below of the various sections of the screen.

Figure 7. The PC Software Display Tab Configures all of the HIM's Display Parameters

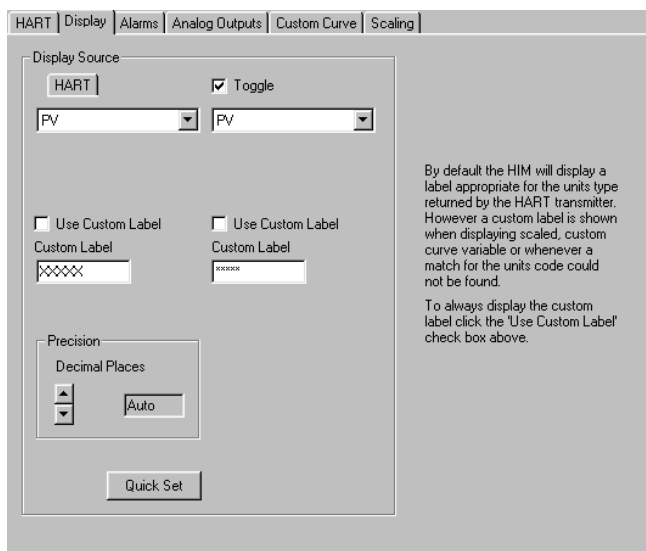

Toggle, Variable List

The *Toggle* checkbox causes the HIM to sequentially display two HART variables in five second increments. Directly below the *Toggle* checkbox are two list boxes to select the variables that you would like to be displayed. Notice that if you select a scaled variable, it is important to check on the *Scaling* page to verify that you have set all of the scaling parameters.

Precision

The *Precision* buttons allow you to change the number of decimal places displayed by the HIM.

Use Custom Label

The *Custom Label* is used to display a calculated or scaled variable. Clicking the *Use Custom Label* box causes the HIM to always display the custom label as Engineering Units (EGU's).

Quick Set

The *Quick Set* button programs the HIM with the information on the Display page.

Programming the Alarms Parameters

The Alarms tab controls the programmable alarm trip(s) option. This screen will be grayed out if the attached HIM is not equipped with at least one alarm trip. To program the Alarm parameters, change the settings in the *Alarm1* and/or *Alarm2* box, then press *Quick Set*. The sections of the screen are described below.

Figure 8. The PC Software's Alarms Tab Configures all of the HIM's Optional (1PRG/2PRG) Alarm Relay Parameters

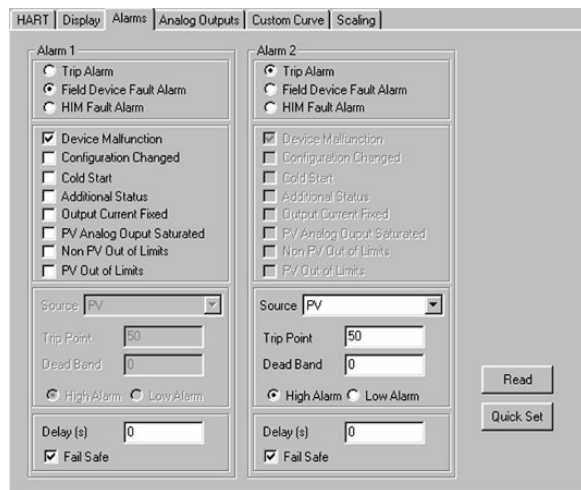

Trip/Fault Alarms

A *Trip Alarm* monitors a selected variable and sets either when the variable exceeds a set value (Trip High) or when the variable falls below a selected value (Trip Low). The *Source* specifies which variable will be monitored, while the *Trip Point* sets the point at which the alarm will trip. After the alarm trips, the *Deadband* determines how far past the trip point the variable will have to go before the alarm condition returns to normal.

There are two types of Fault Alarms. A HIM Fault Alarm monitors the health of the HART monitor. It will trip whenever the internal error status word is set. For example, if the HIM's configuration file becomes corrupt, this alarm will trip and the monitor will display BAD_CONFIG. A Field Device Fault Alarm monitors the health of the HART transmitter. This fault alarm will trip for any of these eight malfunctions:

Device Malfunction (Bit 7)

Relay trips whenever it detects that a hardware error or failure has occurred in the connected HART device.

Configuration Changed (Bit 6)

Relay trips whenever it detects that the connected HART device has had its configuration changed.

Cold Start (Bit 5)

Relay trips whenever the power to the HART device is interrupted. It will also trip during a HART Master Reset or Self Test Command.

Additional Status (Bit 4)

Relay trips whenever the connected HART device reports a condition requiring HART Command #48, which is Read Additional Information. This indicates that the instrument needs attention from a device with full HART command capability.

Output Current Fixed (Bit 3)

Relay trips whenever the HIM detects that the connected HART device's output is no longer responding to changes in its input, and is being held at a predefined level.

PV Analog Output Saturated (Bit 2)

Relay trips whenever it detects that both its analog and digital representations of the Primary Variable are outside rated operating limits, and no longer reflect the true sensor input.

Non-PV Out of Limits (Bit 1)

Relay trips whenever one of the HART ancillary variables (second, third, or fourth), is operating outside the limits that can be effectively measured.

PV Out of Limits (Bit 0)

Relay trips whenever the HART Primary Variable is operating outside the limits that can be effectively measured.

Delay & Fail Safe

By entering a value in the *Delay* box, you can specify how long (in seconds) the alarm condition needs to exist before the alarm trips. *Failsafe* alarms (box checked) de-energize when in alarm condition; *Non-Failsafe* alarms energize when tripped.

Read & Quick Set Buttons

The *Read* button causes the PC Configuration Software to read the alarm information from the attached HIM; The *Quick Set* button causes the software to configure the HIM's alarm settings to match those currently entered in the PC Software.

Programming the Analog Outputs Parameters

The HIM comes with either two (–2AO) or three (–3AO) analog outputs. The *Analog Outputs* tab allows you to specify which HART variable is to be monitored as the source of the analog output, the input range and output range, and how the output will react when the variable input is out of range. To program the Analog Outputs parameters, change the settings in the *Output 1/2/3* boxes, then press *Quick Set*. See the descriptions below of the various sections of the screen.

Figure 9. The PC Software Analog Output Tab Configures all of the HIM's Analog Output Parameters

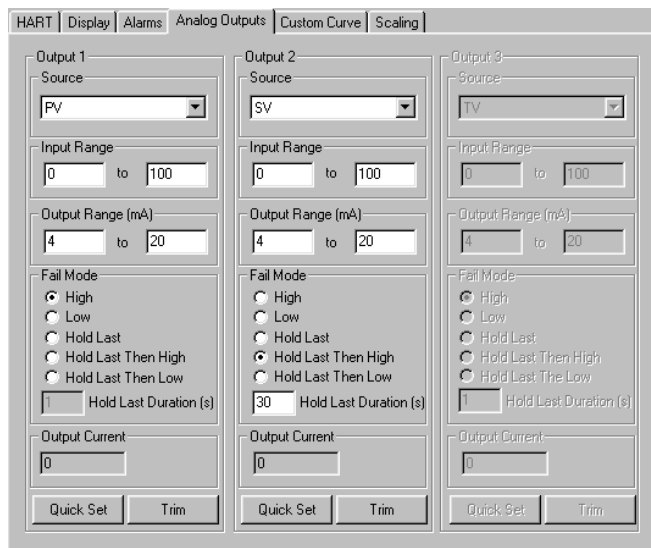

Source

The *Source* defines the variable that the analog output will monitor. Notice that selecting one of the scaled outputs will require you to make changes to the *Scaling* tab, and selecting the Custom Curve option will require you to make changes to the *Custom Curve* tab.

Input/Output Range

The *Input* or *Output Range* defines the range of the source input and the range of the analog output. These two sets of fields can be used to scale the HIM's output.

For example, you have a vortex flow meter with an imbedded RTD that measures the process temperature, and that temperature is assigned to the HART Secondary Variable. The full range of the RTD sensor is from –400°F to +1760°F, but your flow stream will always be between 0° and 400°F. To scale the analog output, for Output 1, set the *Source* as SV. Set the *Input Range* to 0° and 400°, and the *Output Range* to 4mA to 20mA. Click *Quick Set* to download the new configuration file to the HIM.

Output Current Box

The *Output Current* Box on the *Analog Outputs* Tab displays up-to-the-second information on the value, in mA, of the analog output.

Fail Mode

The *Fail Mode* setting determines how the HIM will respond when its monitored input fails. If *Fail Mode* is set to *High* and the measured input goes out of range, or any detected error occurs in the HART transmitter, the analog output will output a 23.6mA signal. If *Fail Mode* is set to *Low* and the measured input goes out of range, or any detected error occurs in the HART transmitter, the analog output will output a signal of 90% of the lower range value below 4mA or 0mA if the lower range is set to 0mA.

If *Fail Mode* is set to *Hold Last*, the HIM will continue to output the last value it recorded before the input failed. If *Fail Mode* is set to *Hold Last Then High* or *Hold Last Then Low*, the HIM will continue to output the last value recorded for a set amount of time (according to *Hold Last Duration* box), then either fail high or fail low, respectively.

Quick Set Button

The *Quick Set* button causes the software to configure the instrument's analog output settings to match those currently entered in the PC Software.

Trim Button

The *Trim* button brings up the Trim Menu, allowing you to set the device's output to match the reading of the loop. Refer to *Programming the Trimming Parameters* on page 17 for more information.

Programming the Custom Curve Parameters

The custom curve tab allows you to set up a custom curve of up to 128 points. A custom curve can either be created from scratch or loaded from a previously created comma separated value (.csv) file. To program the Analog Outputs parameters, change the settings in the *Custom Curve* tab, then press *Download Table*. See the descriptions below of the various sections of the screen.

Figure 10. The PC Software Custom Curve Tab Configures all of the HIM's Custom Curve Parameters

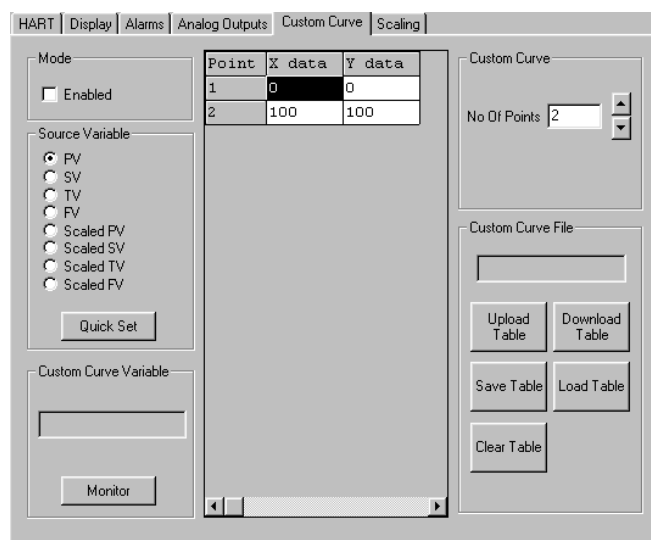

Mode

Check the *Enabled* box to set the Custom Curve mode to *On* and begin programming the custom curve.

Source Variable

The *Source Variable* defines the variable that the custom curve will calculate. Notice that if you select a scaled variable, you may need to click on the *Scale* tab and verify the settings for your scaled variable.

Quick Set

The *Quick Set* button causes the software to configure the HIM's custom curve settings to match those currently entered in the PC Software.

Custom Curve Variable

The *Custom Curve Variable* displays up-to-the-second information on the value of the Custom Curve. Press the *Monitor* button to display the variable information.

Custom Curve

The middle section of the screen displays the custom curve table. After enabling custom curve mode and setting the variable to be monitored, continue by selecting the number of points for the curve. Enter the actual linearization points into the custom curve table, inserting the source variable into the X Column, and the corresponding data (i.e., the °C, °F, Gallons, PSIG, Millimeters, etc.) into the Y Column.

Note:

When entering data in the linearization table, make sure that you enter a number into every open cell.

Custom Curve Files

These buttons allow you to manipulate custom curve files, including the important *Save Table* command that will save a table to your hard drive.

Upload Table

Moves a custom curve file from the connected HIM to the PC Software for editing or storage.

Download Table

Configures the HIM by downloading the custom curve table from the PC Software to the HIM.

Save Table

Saves a displayed custom curve table to memory on your computer's hard drive.

Load Table

Loads a previously saved custom curve table.

Clear Table

Clears the displayed custom curve table.

When you have finished changing all your settings, download the information to the HIM using the *Download Table* button. If you have selected a scaled variable, you should also click on the *Scaling* tab and set the scaling parameters.

Programming the Scaling Parameters

The *Scaling Parameters* tab allows you to configure the values for scaled variables. To scale the selected variable, enter the values into the appropriate boxes, then click on the *Transfer* menu and click *Download* to transfer the new scaled values to the HIM. (If any scaled variable was selected in the Display, Alarm or Analog Output setting tabs, then the corresponding scaled variable section will become active for editing).

The HIM's versatile scaling feature has many possible applications, such as the illustration below.

Suppose you are using a digital pressure (DP) transmitter to measure the level of a tank in either centimeters/inches or PSI. Since the tank is only 300 centimeters (10 feet) high, the full range of the primary variable (PV) output from the DP transmitter is 0-4.3 PSI. You want to display the full level range (in centimeters/inches of water) on the HIM. You also need to control the level from 50% to 100%, since the tank must be at least 50% full at all times. Finally, your existing loop indicator and level controller needs 4-20mA to represent 150 to 300 centimeters (60 to 120 inches) of water. How do you do this?

Scaling Illustration

1. Since you want to display the full level range in inches of water (inH2O) on the HIM, and the HIM is reading PSI as the primary variable, first go to the *Display* tab and select *Scaled PV* as your display source.

Figure 11. The PC Software Scaling Tab Configures all of the HIM's Scaled Variables

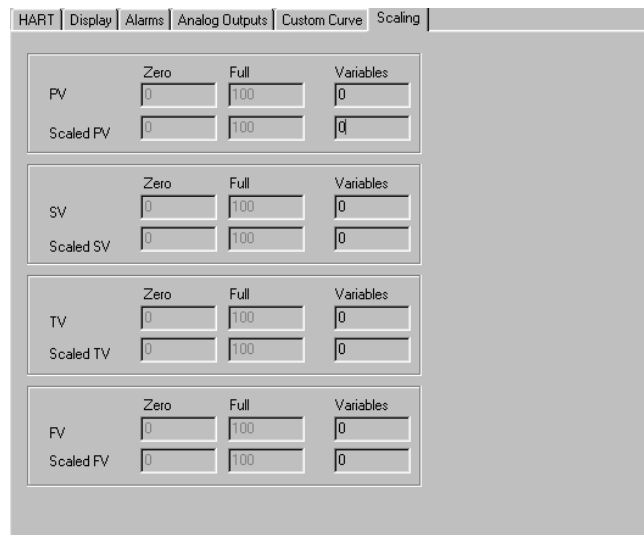

2. Go to the *Scaling* tab and set up the *PV zero* and *PV full* values, and the *Scaled PV zero* and *full* values. *PV zero* would be 0 (PSI) and *PV full* would be 4.3 (PSI). *Scaled PV* would correlate to zero being 0 inH2O and full being 120 inH2O. The HIM should now (after downloading) display the full range in *inH2O*.

3. To manipulate the HIM's analog output, go to the *Analog Output* tab. Select *Scaled PV* as the Output 1 source. Since you need to control the level from 50 to 100%, the *Input Range* should be 60 to 120 inH2O and the *Output Range* should be 4mA to 20mA.

Figure 12. The HIM's Scaling feature works to get the most out of your existing process instruments

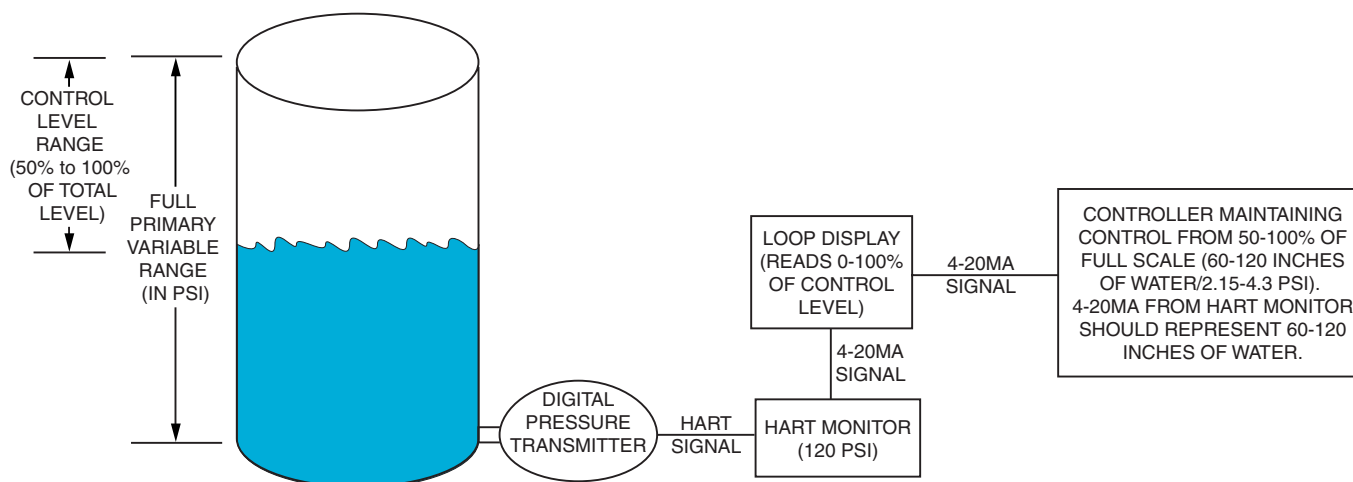

Programming the Trimming Parameters

The *Analog Output Trimming* section of the software allows you to match the HART monitor's analog output to the output measured by a calibration device. This will require a calibrated multimeter, such as a HP Model 3478A or equivalent, accurate to $\pm 0.009\%$. Note that trimming the analog output of the monitor nullifies any scaling that may have been done in the *Scaling* tab.

Figure 13. The PC Software Trimming Tab allows you to Trim the HIM

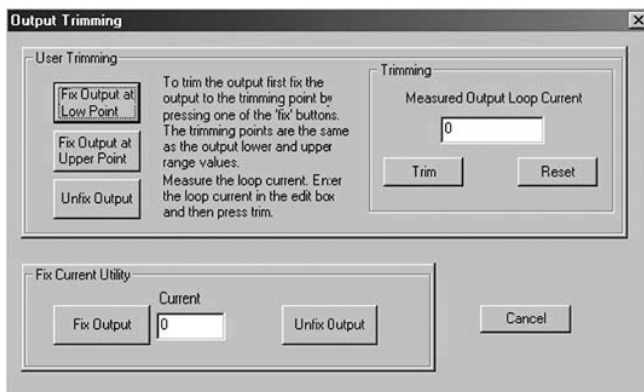

User Trimming

To trim the device, attach a multimeter to the analog output, then press the *Fix Output at Low Point* button. Read the value on the multimeter, enter it into the *Measured Output Loop Current* portion of the *Trimming* box, and press *Trim*. Repeat this sequence until the analog output matches the minimum point (4mA for a 4-20mA output) when you click the *Fix Output at Low Point* button.

After the low point is trimmed, press the *Fix Output at High Point* button. Read the value on the multimeter, enter it into the *Measured Output Loop Current* portion of the *Trimming* box, and press *Trim*. Repeat this sequence until the analog output matches the maximum point (20mA for a 4-20mA output) when you click the *Fix Output at High Point* button.

When finished, press the *Unfix Output* button.

Fix Current Utility

The *Fix Current Utility* allows you to force the HIM to output any current value from 0-20mA. This can be used to match the calibration of your other equipment. To fix the current, simply enter the value in the *Current* box (in mA) that you would output, and press *Fix Output*. When you are finished, make sure to press the *Unfix Output* button so that the HIM can return to normal operation.

HIM

Smart HART® Loop
Interface and Monitor

Figure 14. HIM Dimensions

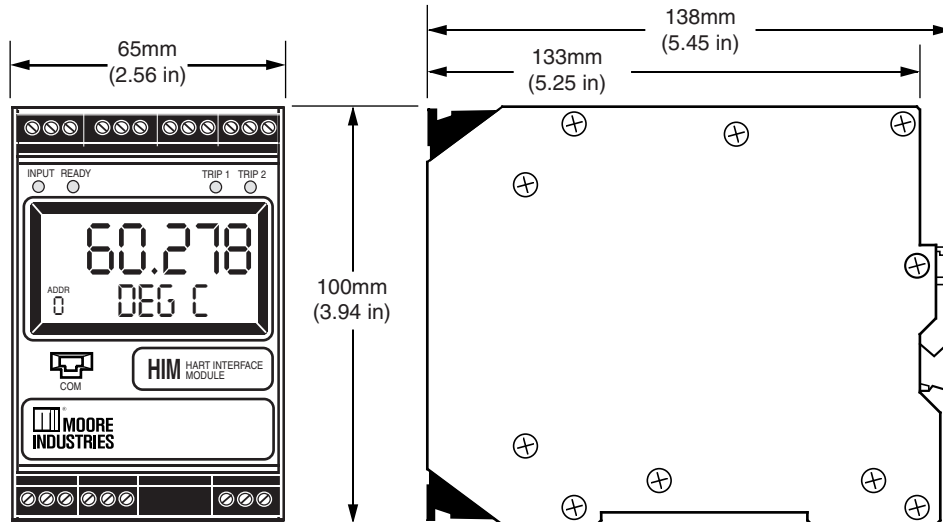

Customer Service

If service assistance is ever required for one of the HIM's in your application, refer to the back cover of this manual for the telephone numbers to Moore Industries STAR Center customer service department.

If possible, make a note of the model number of the offending unit before calling. For fastest assistance, have the following available: serial number and the job and purchase order number under which it was shipped.

Appendix A: Using the HIM MODBUS Feature

The HIM PC program allows you to configure the HART monitor. A HART Monitor with the MODBUS option provides a digital MODBUS output to a connected MODBUS-based controller. Selecting the *MODBUS tab* allows you to set the MODBUS communications parameters. Notice that the *MODBUS tab* will only be available in units with the MODBUS option.

Figure A-1. MODBUS Screen

The screenshot shows the HIM software interface for configuring MODBUS settings. At the top, there is a menu bar with options: HART, Display, Alarms, Custom Curve, Scaling, and MODBUS. The MODBUS tab is currently active. Below the menu bar, the 'Comms Settings' section is visible, containing three main configuration areas: 1. 'MODBUS Address (Dec)': A numeric input field showing '1' with left and right arrow buttons for navigation. 2. 'Baud Rate': A dropdown menu currently set to '9600'. 3. 'Parity': A dropdown menu currently set to 'None'. Below this section is the 'Floating Point Word Order' section, which has two radio button options: 'Standard LSW' (which is selected) and 'Swapped MSW'.

Comms Settings

The Comms Settings include three settings:

MODBUS Address

The *MODBUS Address* is the number that the HIM monitor uses to identify itself on the MODBUS network. The MODBUS address is configurable from 1 to 247. By default, it will assume a MODBUS address of 01.

Baud Rate

The *Baud Rate* is the speed of data transmission. It should be set to match the baud rate of the attached controller. The interface supports the following baud rates: 300, 600, 1200, 2400, 4800, 9600, and 19200.

Parity

The HART monitor supports even, odd and no *Parity*. The data format is one start bit, 8 data bits and one stop bit.

Floating Point Word Order

By default, the HART monitor will use the *Standard LSW* (least significant word) floating point word order format. This stores the most significant bits in the second register and the least significant bits in the first register. Selecting *Swapped MSW* (most significant word) will reverse the order, storing the most significant bits in the first register and the least significant bits in the second register.

MODBUS Registers

The HART Monitor outputs a MODBUS signal to the attached controller. To access the MODBUS registers for variable, input/output, or error information, see the MODBUS Register Definitions table or System Register table on the following pages.

HIM

Smart HART® Loop
Interface and Monitor

Figure A-2. Installing a HIM with MODBUS output into the loop using the Transmitter Excitation (+TX) terminal

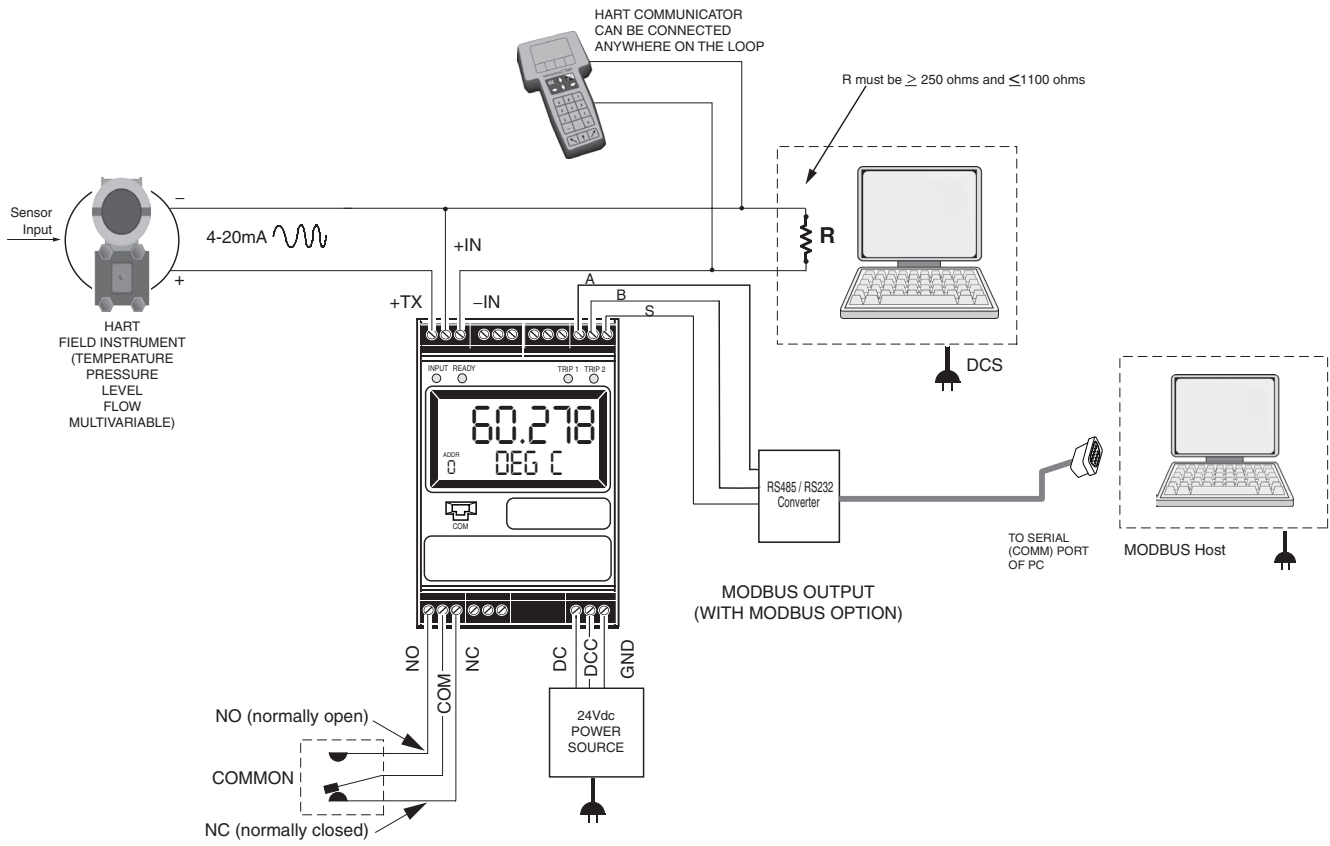

Table A-1. MODBUS Register Definitions

Register Range	Description
0	HART Primary variable
1	HART Secondary variable
2	HART Third variable
3	HART Fourth variable
4	PV scaled
5	SV scaled
6	TV scaled
7	FV scaled
8	Linearized variable
9	Analog Output 1 current x 100mA
10	Analog output 2 current x 100mA
11	Analog output 3 currentx 100mA
12	HIM Status Information Bit 0 = hardware failure Bit 1 = EEPROM fail Bit 2 = EEPROM configuration checksum error Bit 3 = EEPROM calibration checksum error Bit 4 = EEPROM blank Bit 5 = Out of range error Bit 6 = Division by zero error Bit 7 = Configuration data bad error Bit 8 = COP SW fail Bit 9 = RAM test fail Bit 10-13 = not used Bit 14 = HART device malfunction status bit set Bit 15 = No HART communications status
13	HART status information (as per HART specification)

14	HART instrument PV EGU (MSB = 0, LSB = HART EGU code)
15	HART instrument SV EGU (MSB = 0, LSB = HART EGU code)
16	HART instrument TV EGU (MSB = 0, LSB = HART EGU code)
17	HART instrument QV EGU (MSB = 0, LSB = HART EGU code)
18	Device ID MSW
19	Device ID LSW
20	HART Device Manufacturer ID
21	HART Device, device type code
22	HART device, device ID MSW
23	HART Device, device ID LSW
24	HIM Alarm Status (Bit 0 = alarm 1, Bit 2 = alarm 2)
256-257	HART Primary variable (float format)
258-259	HART Secondary variable (float format)
260-261	HART Third variable (float format)
262-263	Hart Fourth variable (float format)
264-265	Scaled Primary variable (float format)
266-267	Scaled Secondary variable (float format)
268-269	Scaled Third variable (float format)
270-271	Scaled Fourth variable (float format)
272-273	Linearized variable (float format)
274-275	Analog output 1 current x 100mA
276-277	Analog output 2 current x 100mA
278-279	Analog output 3 current x 100mA

Table A-2. System Status Registers

MSB/LSB Int 16 (16 bit integer)	Bit Position	Description
MSB = device status	Bit 7	HART device no comms
	Bit 6	HART device malfunction
LSB = device error code	Bit 0	HW fail
	Bit 1	EEPROM fail
	Bit 2	EEPROM checksum error
	Bit 3	EEPROM calib data error
	Bit 4	EEPROM blank
	Bit 5	out of range value
	Bit 6	division by zero
	Bit 7	bad configuration

RETURN PROCEDURES

To return equipment to Moore Industries for repair, follow these four steps:

1. Call Moore Industries and request a Returned Material Authorization (RMA) number.

Warranty Repair –

If you are unsure if your unit is still under warranty, we can use the unit's serial number to verify the warranty status for you over the phone. Be sure to include the RMA number on all documentation.

Non-Warranty Repair –

If your unit is out of warranty, be prepared to give us a Purchase Order number when you call. In most cases, we will be able to quote you the repair costs at that time. The repair price you are quoted will be a "Not To Exceed" price, which means that the actual repair costs may be less than the quote. Be sure to include the RMA number on all documentation.

2. Provide us with the following documentation:
 - a) A note listing the symptoms that indicate the unit needs repair
 - b) Complete shipping information for return of the equipment after repair
 - c) The name and phone number of the person to contact if questions arise at the factory
3. Use sufficient packing material and carefully pack the equipment in a sturdy shipping container.
4. Ship the equipment to the Moore Industries location nearest you.

The returned equipment will be inspected and tested at the factory. A Moore Industries representative will contact the person designated on your documentation if more information is needed. The repaired equipment, or its replacement, will be returned to you in accordance with the shipping instructions furnished in your documentation.

WARRANTY DISCLAIMER

THE COMPANY MAKES NO EXPRESS, IMPLIED OR STATUTORY WARRANTIES (INCLUDING ANY WARRANTY OF MERCHANTABILITY OR OF FITNESS FOR A PARTICULAR PURPOSE) WITH RESPECT TO ANY GOODS OR SERVICES SOLD BY THE COMPANY. THE COMPANY DISCLAIMS ALL WARRANTIES ARISING FROM ANY COURSE OF DEALING OR TRADE USAGE, AND ANY BUYER OF GOODS OR SERVICES FROM THE COMPANY ACKNOWLEDGES THAT THERE ARE NO WARRANTIES IMPLIED BY CUSTOM OR USAGE IN THE TRADE OF THE BUYER AND OF THE COMPANY, AND THAT ANY PRIOR DEALINGS OF THE BUYER WITH THE COMPANY DO NOT IMPLY THAT THE COMPANY WARRANTS THE GOODS OR SERVICES IN ANY WAY.

ANY BUYER OF GOODS OR SERVICES FROM THE COMPANY AGREES WITH THE COMPANY THAT THE SOLE AND EXCLUSIVE REMEDIES FOR BREACH OF ANY WARRANTY CONCERNING THE GOODS OR SERVICES SHALL BE FOR THE COMPANY, AT ITS OPTION, TO REPAIR OR REPLACE THE GOODS OR SERVICES OR REFUND THE PURCHASE PRICE. THE COMPANY SHALL IN NO EVENT BE LIABLE FOR ANY CONSEQUENTIAL OR INCIDENTAL DAMAGES EVEN IF THE COMPANY FAILS IN ANY ATTEMPT TO REMEDY DEFECTS IN THE GOODS OR SERVICES, BUT IN SUCH CASE THE BUYER SHALL BE ENTITLED TO NO MORE THAN A REFUND OF ALL MONIES PAID TO THE COMPANY BY THE BUYER FOR PURCHASE OF THE GOODS OR SERVICES.

ANY CAUSE OF ACTION FOR BREACH OF ANY WARRANTY BY THE COMPANY SHALL BE BARRED UNLESS THE COMPANY RECEIVES FROM THE BUYER A WRITTEN NOTICE OF THE ALLEGED DEFECT OR BREACH WITHIN TEN DAYS FROM THE EARLIEST DATE ON WHICH THE BUYER COULD REASONABLY HAVE DISCOVERED THE ALLEGED DEFECT OR BREACH, AND NO ACTION FOR THE BREACH OF ANY WARRANTY SHALL BE COMMENCED BY THE BUYER ANY LATER THAN TWELVE MONTHS FROM THE EARLIEST DATE ON WHICH THE BUYER COULD REASONABLY HAVE DISCOVERED THE ALLEGED DEFECT OR BREACH.

RETURN POLICY

For a period of thirty-six (36) months from the date of shipment, and under normal conditions of use and service, Moore Industries ("The Company") will at its option replace, repair or refund the purchase price for any of its manufactured products found, upon return to the Company (transportation charges prepaid and otherwise in accordance with the return procedures established by The Company), to be defective in material or workmanship. This policy extends to the original Buyer only and not to Buyer's customers or the users of Buyer's products, unless Buyer is an engineering contractor in which case the policy shall extend to Buyer's immediate customer only. This policy shall not apply if the product has been subject to alteration, misuse, accident, neglect or improper application, installation, or operation. THE COMPANY SHALL IN NO EVENT BE LIABLE FOR ANY INCIDENTAL OR CONSEQUENTIAL DAMAGES.



The Interface Solution Experts • www.miinet.com

United States • info@miinet.com
Tel: (818) 894-7111 • FAX: (818) 891-2816
Australia • sales@mooreind.com.au
Tel: (02) 8536-7200 • FAX: (02) 9525-7296

Belgium • info@mooreind.be
Tel: 03/448.10.18 • FAX: 03/440.17.97
The Netherlands • sales@mooreind.nl
Tel: (0)344-617971 • FAX: (0)344-615920

Shanghai • sales@mooreind.sh.cn
Tel: 86-21-62481120 • FAX: 86-21-62490635
United Kingdom • sales@mooreind.com
Tel: 01293 514488 • FAX: 01293 536852